



UHS Battery Burnisher
PE300BU
Operator's Manual



Instructions For Use

Failure to read and understand this manual before operating this machine or performing service on this machine may result in injury to the operator or nearby personnel or result in damage to the machine or nearby property. Each operator must be trained in the operation of this machine before being allowed to use it. Contact Amano Pioneer Eclipse Customer Service at 1-800-367-3550 or +1-336-372-8080 or an authorized Amano Pioneer Eclipse Distributor to inquire about training or to request a replacement manual.

NOTICE

Proper maintenance is necessary with all battery powered floor machines. Following the scheduled maintenance procedures found in your operation manual will provide many years of uninterrupted service.



In addition to the scheduled maintenance procedures listed it is recommended to have your machine serviced by certified service personnel every three months. This service should include an emissions check.

! FOR YOUR SAFETY !

DO NOT store or use gasoline or other flammable vapors and liquids in the vicinity of this or any or other appliance.

Record This Important Information

Date of Purchase _____

Purchased From _____

Address _____

City _____ State _____ Zip _____

Phone _____ Contact _____

Machine Model _____

Machine Serial Number _____

Important Phone Numbers

Medical Emergency _____

Police _____

Fire Department _____

In this Operation Manual you will find three statements that you must read and observe to ensure safe operation of this machine.

DANGER! indicates that the possibility of severe bodily injury or death can occur if DANGER! statements are ignored. Read and observe all DANGER! statements included in the Operation Manual and attached to the machine.

WARNING! indicates that the possibility of bodily injury to the operator and other people can occur if WARNING! statements are ignored. Read and observe all WARNING! statements included in the Operation Manual and attached to the machine.

CAUTION! indicates that the possibility of damage to the machine or other property can occur if CAUTION! statements are ignored. Read and observe all CAUTION! statements included in the Operation Manual and attached to the machine.

Table of Contents

Quick Reference Specifications.....	4	Changing Direction.....	14
Safety Precautions.....	6	Stopping & Turning off Machine.....	14
Operator Responsibility.....	7	Operation on Inclines.....	14
Test for Operator-Ear Sound Pressure Level.....	7	Installing / Changing Burnishing Pad.....	14
Test for Hand Arm Vibration.....	7	Dust Bag Removal (20", 24").....	15
Machine Preparation.....	8	Dust Bag Removal (27"/28").....	15
Unpacking the Machine.....	8	Caster Parking Brake.....	15
Machine Storage.....	8	Pad Pressure Adjustment.....	15
Repacking the Machine.....	8	Post Operation Checklist.....	15
Transporting the Machine.....	8	Maintenance.....	16
Connecting the Batteries.....	9	Scheduled Maintenance.....	16
Installing the Skirt.....	9	Body & Battery Cover.....	17
Machine Components.....	10	Battery Maintenance.....	17
Traction Model.....	11	Lead Acid Batteries.....	17
Key Switch.....	11	Rear Casters.....	18
Handle Lever.....	11	Belt Maintenance.....	18
Burnish Switch.....	11	Belt Replacement.....	18
Reverse Switch.....	11	Alarm Codes.....	19
Traction Speed Control.....	11	Machine Troubleshooting.....	20
Hour / Battery Meter.....	11	Machine Specifications.....	21
Alarm LED.....	11	Parts Manual.....	22
Pad Assist Model.....	11	Electrical Schematic - Pad Assist.....	23
Key Switch.....	11	Electrical Schematic - Traction.....	24
Handle Lever.....	11	Connections - Pad Assist.....	25-26
Burnish Switch.....	11	Connections - Traction.....	27-28
Hour / Battery Meter.....	11	Skirt, Deck & Axle Bracket Assembly.....	29-30
Over Current Protection.....	11	Head Axle Bracket Assembly.....	31-32
Onboard Battery Charger.....	12	Main Bottom Assembly - Pad Assist.....	33-34
Battery Charger Controls.....	12	Main Bottom Assembly - Traction.....	35-36
Battery Charger Settings.....	13	27"/28" Main Bottom Assembly.....	37-38
Battery Charger Fault Codes.....	13	Main Rear Assembly.....	39-40
How the Machine Works.....	14	Main Top Assembly.....	41-42
Pre-Operation Checklist.....	14	Main Front Assembly.....	43-44
Turning on the Machine.....	14	27"/28" Front Assembly.....	45-47

Quick Reference

Specifications:

- Voltage: 36VDC (Qty. 3 - 12VDC Batteries)
- Burnish Rate: $\pm 26,000$ ft²/hr (2415 m²/hr) [20"]
 $\pm 31,200$ ft²/hr (2899 m²/hr) [24"]
 $\pm 36,400$ ft²/hr (3382 m²/hr) [27"/28"]
- Overload Protection: Resettable Breakers
- Operating Time: Approximately 3 hours
- Pad Pressure: Adjustable

Routine Maintenance Parts:

- Cloth Dust Bag: MP414100 [20", 24"]
MP469300 [27"/28"]
- Paper Dust Bag: MP414200 (3 Per Pack)
- Pad Holder: MP414000 [20"]
MP435000 [24"]
MP529400 [27"/28"]
- Pad Retainer: MP432400
- 3A Glass Fuse: MP234700
- Charger Fuse: MP265100 (115V)
MP289100 (230V)
- Steel Skirt: MP425200 [20"]
MP434200 [24"]
MP526200 [27"/28"]
- Skirt Edging: MP139800 - 6 ft (183 cm) [20"]
MP139800 - 7 ft (214 cm) [24"]
MP139800 - 8 ft (244 cm) [27"/28"]
- Battery: MP223500 (12V Lead Acid) Qty. 3
MP413600 (12V AGM) Qty. 3
- Gas Spring: MP415200 [20"]
MP434500 [24"]
MP505500 [27"/28"]
- Burnish Motor Brush Kit: MP433200
- Transaxle Motor Brush Kit: MP433300

Your Authorized Amano Pioneer Eclipse Distributor: _____

Authorized Amano Pioneer Eclipse Distributor Phone Number: _____

Amano Pioneer Eclipse Phone Number: +1-336-372-8080

Safety Precautions

Anyone operating the machine should read the following carefully and be informed of potentially dangerous operating conditions. Operators should be familiar with the location and use of all safety devices on the machine. DO NOT use the machine if it is not in proper operating condition, and report any damage or operation faults immediately.

DANGER! This machine has parts including the pad/brush assemblies that can cause severe injury if these parts are contacted while they are moving. **DO NOT** allow any part of the body or clothing to come in contact with these parts while they are moving. **DO NOT** try to change the pads/brushes while the machine is running. **DO NOT** allow other people to come near the machine while it is in operation. **DO NOT** allow the machine to run unattended. **DO NOT** leave the machine in a place where unauthorized or untrained personnel could use the machine. **DO NOT** run the machine with the pads/brushes off center, damaged or missing. **DO NOT** operate the machine if the machine has loose parts.

WARNING! Batteries emit hydrogen gas. Explosion or fire can result. Keep sparks and open flame away. Keep covers open when charging. **DO NOT** smoke around batteries. Avoid skin contact with the acid contained in the batteries. Never allow metal objects to lay across battery tops.

WARNING! Operate from the rear of the machine only.

WARNING! Inspect pad holders regularly. A fractured pad holder may result in pad fragments causing injury.

WARNING! Use caution when operating the machine on a ramp or incline. **DO NOT** turn the machine, or leave it unattended, on a ramp or incline.

WARNING! Store machine inside. Keep the electrical components of the machine dry. **DO NOT PRESSURE WASH MACHINE.**

WARNING! Modifications or alterations to this machine can lead to personal injury or damage to the machine. **DO NOT** make unauthorized modifications or alterations to this machine. Amano Pioneer Eclipse assumes no liabilities for injury or damage resulting from an unauthorized modification or alteration to the machine. Any unauthorized modification or alteration to this machine voids all warranties.

WARNING! The motor and motor controller become hot enough while the machine is in operation, and for a long time after the machine is shut off, to cause severe burns. **DO NOT** touch these parts of the machine until they have cooled.

WARNING! Injury can occur to the eyes and body while using the machine. Safety goggles, safety shoes, and safety clothing are recommended while operating the machine.

WARNING! Machine vibration may cause tingling or numbness in the fingers or hands. Gloves are recommended to reduce machine vibration. If tingling or numbness persists, shut off the machine. If the vibration is caused by loose parts such as an off center pad/brush, adjust or tighten these parts before using the machine again.

WARNING! DO NOT burnish on an incline. This machine is designed to burnish on a flat level floor.

CAUTION! DO NOT operate machine unless trained and authorized. **DO NOT** operate machine unless you have read and understand the operation manual. **DO NOT** operate machine in flammable or explosive areas.

CAUTION! Before starting machine ensure all safety devices are in place and functioning properly. Before starting machine check for proper operation.

CAUTION! When using machine, go slowly on inclines or slippery surfaces. Use care when operating machine in reverse. Follow all manufacturers instructions on chemical product containers when handling, mixing, or using chemical products.

CAUTION! When servicing machine, stay clear of moving parts. **DO NOT** wear loose clothing when working on machine. Block machine wheels before raising or jacking up machine. Use hoist stands that will support the weight of the machine. Wear eye and ear protection when using pressurized air. Disconnect battery connections before servicing machine. Use only replacement parts supplied by Amano Pioneer Eclipse or a Amano Pioneer Eclipse Authorized Distributor or Service Center.

This machine is manufactured for commercial use only.

This machine is designed and manufactured for burnishing indoor hard floor surfaces. Amano Pioneer Eclipse does not recommend use of this machine in any environment other than an indoor environment.

Battery powered floor equipment is designed and manufactured for commercial use only. These machines are designed to burnish most modern types of floors including composition tile, stone, marble, terrazzo, and resilient floor covering, and some coated wood floors.

These machines should not be used

- By unqualified or untrained personnel.
- Unless properly maintained and adjusted.
- On areas with obstructions such as thresholds, floor outlet boxes, etc.
- In areas where loose debris or other objects are present.

Operator Responsibility

The operator is responsible for performing the recommended daily maintenance and checkups of the machine to keep it in good working condition. The operator must inform the service mechanic or supervisor when recommended maintenance procedures are required as described in the "MAINTENANCE" section of this manual.

- Read this manual carefully before operating this machine.
- FOR SAFETY: **DO NOT** operate machine before reading and understanding the operation manual.
- Check the machine for shipping damage.

Keep your machine regularly maintained by following the maintenance information in this manual. Order parts and supplies only from an Authorized Amano Pioneer Eclipse Distributor. Use the parts illustration section of your manual when ordering parts. During and after operation, perform the recommended daily and hourly procedures outlined in the Maintenance Chart.

Test for Operator-Ear Sound Pressure Level

Amano Pioneer Eclipse measures and rates the operator-ear sound pressure level for hand-guided floor treatment and floor cleaning machines for industrial use. All tests are performed in accordance with European Machinery Directive (2006/42/EC).

- Outdoor test area consists of a flat open space free from effects of signboards, buildings or hillsides for at least 15 m (50 ft) from the center of the test surface. Indoor tests are conducted in a semi-anechoic or sound deadening room.
- The test surface is a single sheet of floor covering at least 1 m (3.3 ft) wider and longer than the equipment being tested. In order to not affect the sound reading, the observer taking readings is at least 2 m (6.6 ft.) from the equipment being tested, or standing directly behind the operator.
- All machines are tested while stationary and centered on the test surface. With the traction drive in neutral (where applicable) the test is conducted with the machine at maximum engine or motor speed as specified by the manufacturer.
- The operator is located in the normal operating position with the microphone or meter supported independent of the machine, 1,68 m (66 in) above the test surface, 25 cm (10 in) to the right and left centerline of the operators position, and 20 cm (8 in) to the rearmost point of the handle, with the handle in the most forward position.
- The sound level meter is observed for a minimum of 5 seconds or until a stabilized reading is obtained. The maximum repeatable sound level observed during the test at each microphone position is recorded and documented.

Test for Hand-Arm Vibration at the Grip Surface of Hand-Guided Machinery

Amano Pioneer Eclipse measures and rates the vibration at the machine-hand contact surface of hand-guided machines that are provided with handles in accordance with European Machinery Directive (2006/42/EC).

- The test area consists of a flat open floor area that allows the machine to be operated normally.
- The transducer is mounted firmly at a point halfway along the length of the handle where the handle would normally be held.
- Machines are tested while stationary, with all mechanisms necessary for the equipment to perform its intended functions engaged and the traction drive in neutral (if applicable). The machine will be tested at maximum engine or motor speed as specified by the manufacturer of the subject machine.
- The measurements are recorded from the dominant axis.

Machine Preparation

Unpacking the Machine

The machine is shipped boxed on a wooden pallet. To unpack machine:

1. Cut and remove bands holding the box to the pallet.
2. Remove staples attaching the box to the platform at the bottom edge of the box.
3. With two people, one at either end of the box, lift box straight up and off machine.
4. Remove loose accessories from the top of machine.
5. Cut and remove bands securing the machine to the pallet.
6. Remove the wooden wheel stops. The wheel stops can be placed on the floor next to the pallet and used as a step as the machine is lowered.
7. Carefully back the machine off of the pallet.

NOTE: *If unpacking the 27"/28" machine, consider removing the skirt prior to backing the machine off of the pallet (see Installing / Removing The Skirt on Page 9)*

Machine Storage

1. Machine should be stored in a dry environment.
2. Store machine away from objects that may fall and damage it.
3. Never store burnisher near an open flame or heat producing device.
4. Make sure burnisher is cleaned properly by wiping machine down with damp cloth before storing.

CAUTION! NEVER PRESSURE WASH MACHINE!

5. Disconnect batteries before storage.

Repacking the Machine

Refer to Unpacking section on page 8 and repack machine using original packing materials and container.

Transporting the Machine

When shipping the machine, make sure the batteries are disconnected and the machine is secured in the transporting vehicle.

Connecting the Batteries

1. Place the batteries in the machine oriented as shown in diagram.
2. Connect the batteries as shown in the battery connection diagram.
3. **DANGER! Incorrect connection of batteries can cause explosion and/or serious injury.**
4. Double check battery connections.
5. Connect the battery pack plug to the machine.

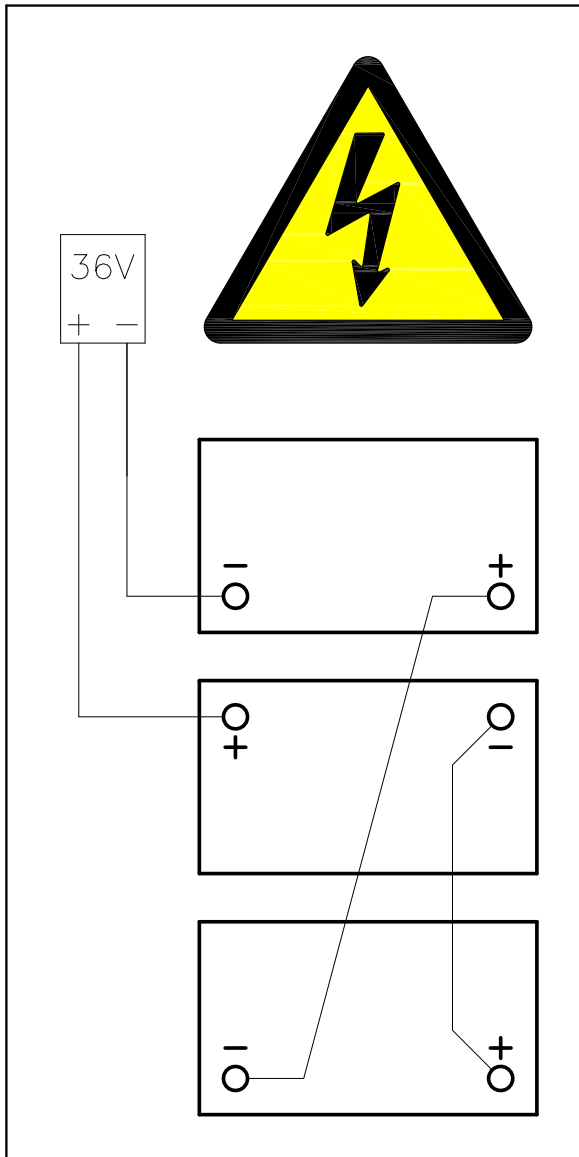

Installing / Removing The Skirt

NOTE: The machine will come with the skirt attached, if installation or removal is needed, follow instructions below:

1. Lift the deck upward about 90 degrees by pulling up on the front of the deck. At this point, the tilt latch will hold the deck in the pad change position. (Ref. Machine Operation - Installing/Changing Burnishing Pad)
2. From the outside of the skirt, loosen the 1/4" hex bolt with a jam.
3. **Applies to 20" and 24" machines:** Slide the skirt onto the burnish head aligning the slots in the skirt with the tabs on the deck. Make sure the 1/4" bolt is at the back of the shroud.

Applies to 27" and 28" machines: Slide the skirt onto the machine fully by holding it perpendicular to the burnish head, and working it toward the burnish motor. Then rotate it down and into place with the ears aligned properly. (One ear will rest between the knob and dust control pipe on the shroud.)



4. Tighten the 1/4" bolt until the skirt is snug around the deck but also floats up and down freely.
5. Tighten jam nut and lower deck to burnish position. (Ref. Machine Operation: Installing/Changing Burnishing Pad)
6. To Remove the skirt, loosen the 1/4" hex bolt (if needed) and either disengage the slots from the tabs on the deck (20", 24" machines) or lift the skirt toward the burnish motor to disconnect from the burnish head (27"/28" machine).

Work the skirt down and around the burnish head to remove.

Machine Components

Controls and Instruments

Traction

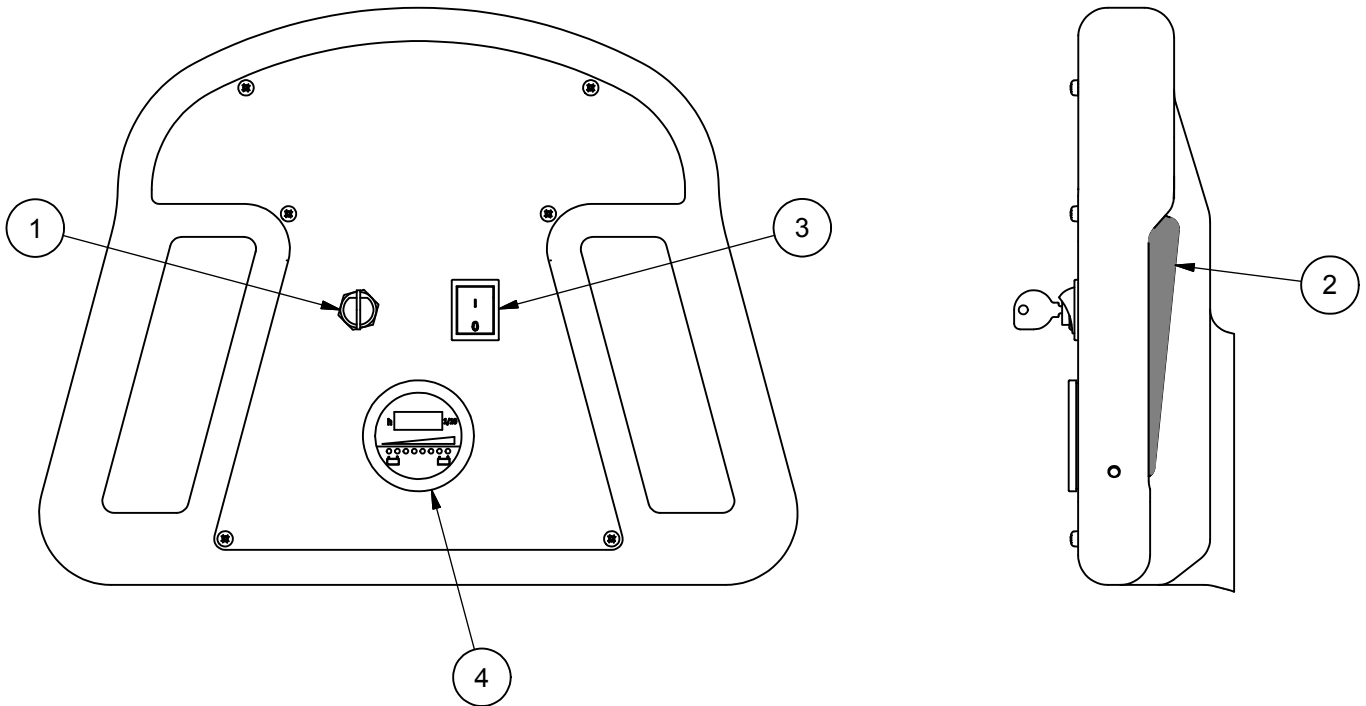
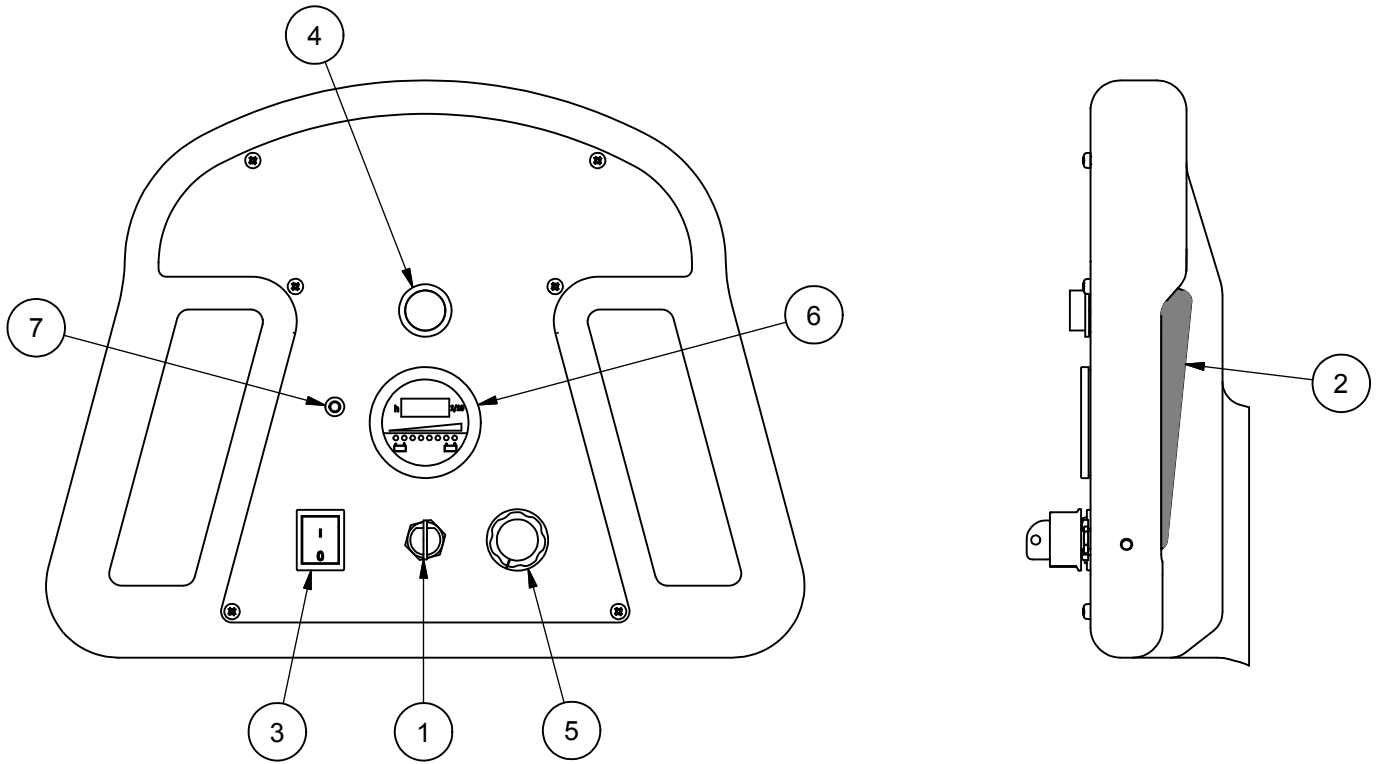

Pad Assist

300BU Traction Model

1. **Key Switch** - Turns the machine on/off.
2. **Handle Lever** - When the lever is engaged the machine will move forward. If the Burnish switch is on, the pad will also start turning. If the burnish head is tilted up into the pad change position, the burnish motor will not engage.

NOTE: The machine needs to be moving when the burnish switch is turned on or off in order to keep from burning the floor.

3. **Burnish Switch** - Turns burnish function on/off. The burnish motor will not engage unless the burnish switch is on and the handle lever is engaged. If the burnish head is tilted up into the pad change position, the burnish motor will not engage.
4. **Reverse Switch** - Hold down this switch while the handle lever is engaged and the machine will move in reverse. Once the reverse switch is released the machine will start moving forward.
5. **Traction Speed Control** - Turn the knob clockwise to increase speed. Turn the knob counter-clockwise to decrease speed.
6. **Hour Meter / Battery Discharge Indicator** - The LCD displays the number of burnishing hours. The machine will only count hours while burnishing. The row of LEDs display the charge level of the battery pack. When all the yellow LEDs are lit, the battery pack is fully charged. In order to protect the battery pack, when the red LED is lit, the burnish motor will stop and the machine should be recharged.
7. **Alarm LED** - Displays trouble codes as a blink pattern. In normal operation this LED will be off. If it comes on, refer to the troubleshooting section.

300BU Pad Assist Model

1. **Key Switch** - Turns the machine on/off.
2. **Handle Lever** - When the lever is engaged, if the burnish switch is on, the pad will start turning. If the burnish head is tilted up into the pad change position, the burnish motor will not engage.

NOTE: The machine needs to be moving when the burnish switch is turned on or off in order to keep from burning the floor.

3. **Burnish Switch** - Turns burnish function on/off. The burnish motor will not engage unless the burnish switch is on and the handle lever is engaged. If the burnish head is tilted up into the pad change position, the burnish motor will not engage.
4. **Hour Meter / Battery Discharge Indicator** - The LCD displays the number of burnishing hours. The machine will only count hours while burnishing. The row of LEDs display the charge level of the battery pack. When all the yellow LEDs are lit the battery pack is fully charged. In order to protect the battery pack, when the red LED is lit the burnish motor will stop and the machine should be recharged.

Over Current Protection

1. 70A Breaker - Over current protection for the burnish motor. Push to reset.
2. 40A Breaker - Over current protection for the traction drive. Push to reset (Only on Traction models).
3. 3A Fuse In-Line holder - Over current protection for key switch.



Onboard Battery Charger

To charge the batteries, first drive the machine to a flat, dry, well-ventilated area then turn the machine off. If using lead acid batteries, check the water level in all the battery cells (see *Battery Maintenance* section). If the level is low, add just enough distilled water to cover the plates. ****DO NOT OVERFILL!****



Then plug the charger cord into a wall socket. The battery charger will initialize and then soft start the charging cycle.

WARNING! Batteries emit hydrogen gas when charging. Explosion or fire can result. Keep sparks and open flame away when charging.

CAUTION! When servicing machine, wear protective gloves and goggles when handling batteries or battery cables. Avoid contact with battery acid.

Battery Charger Controls

1. Three-digit display + symbol (1), to view A=charging current, U=battery voltage, h=charging time, C=charging ampere-hours (AH), E=energy used to charge (KWh)
2. Button for the Selection of the display mode (2): A, U, h, C, E. After 10 seconds the display returns to the display of charging current.
3. Red control indicator (3): when it is on, the charging cycle has started.
4. Yellow control indicator (4): when it is on, the final phase of the charging cycle has started.
5. Green control indicator (5): when it is on, the charging cycle has finished.

Once the charge cycle is complete, the charger will remain active in a trickle charge mode to maintain the charge on the batteries until the charger is unplugged from the wall socket.

FRONT PANEL OF BATTERY CHARGER MODEL CBHF2

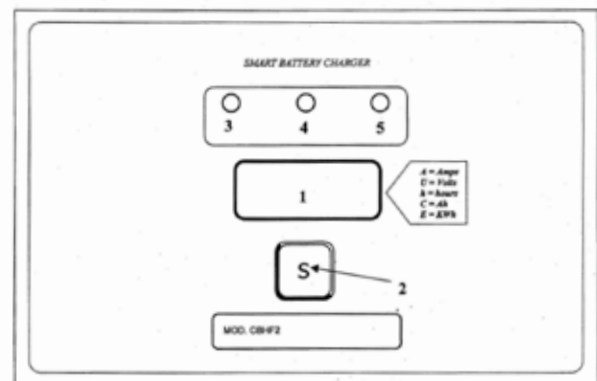

Charger Settings

The On-Board battery charger settings need to be set for your battery type before charging. Failure to properly set will result in battery damage.

To determine your battery type, see battery label or contact your battery supplier.

To change charger settings:

1. Unplug the charger.
2. Peel back the corner of the display label.
3. Set the DIP switches, according to your battery pack, as shown below. If your battery pack type is not listed please call Amano Pioneer Eclipse at +1 -336-372-8080 for correct setting.



LEAD ACID BATTERY DIP SWITCH CONFIGURATION

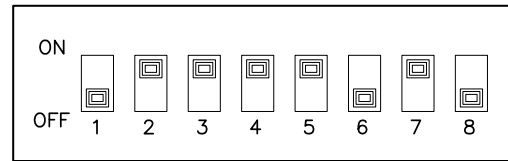

DISCOVER SEALED BATTERY DIP SWITCH CONFIGURATION

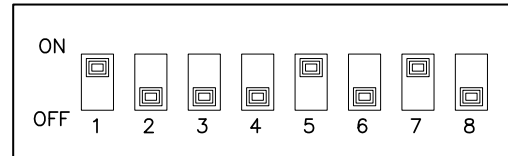

FULL RIVER SEALED BATTERY DIP SWITCH CONFIGURATION

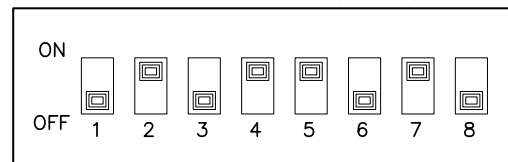

Battery Charger Fault Codes

Fault	Description	Remedy
No Display	No display on the charger, no LED indicators.	Check that the plug is connected to an operating wall outlet. Check fuse. 20A fuse MP265100.
b2t	Incorrect battery connection or no battery connection.	Check the connection and the polarity of the battery connection.
E01	The maximum voltage admissible by the battery has been exceeded. The charge cycle was interrupted.	Restart the charge cycle. If problem persists, battery pack may be damaged.
E02	The maximum temperature has been exceeded. The charge cycle was interrupted.	Restart the charge cycle. If problem persists, battery pack may be damaged.
E03	The maximum time for the charging phase has been exceeded. The charge cycle was interrupted.	Restart the charge cycle. If problem persists, battery pack may be damaged.
S2t	The total safety time has interrupted the charge cycle.	Restart the charge cycle. If problem persists, battery pack may be damaged.
Sr t	Internal charger fault.	Replace battery charger.

How the Machine Works

The Burnish components of the machine are:

- Burnish pad holder
- Burnish pad
- Burnish motor
- Dust Collection Bag

As the machine moves forward, the burnish pad shines the floor. Any excess dirt or wax gets picked up by the pad and distributed into the dust collection bag via the dust collection system.

Pre-Operation Checklist

Before operating the machine:

- Check that the Burnish Switch is in the off position.
- Check the pad holder to ensure there are no breaks or cracks.
- Check correct connection of the batteries.
- Check that the Dust Collection Bag is empty.
- Release caster breaks.

Turning on the Machine

1. Complete pre-operation check.
2. Turn the Key to the ON position.
3. Turn on the burnish switch and engage the handle levers.
4. Adjust speed as needed with traction speed control knob. (Traction Models Only)

Changing Direction

When the handle levers are engaged the machine will travel in the forward direction. To travel in reverse, while the handle levers are engaged, hold down the reverse switch. The machine will change from forward direction to reverse direction. The machine will continue in the reverse direction until the reverse switch is released.

Stopping & Turning Off Machine

To stop the machine, release the handle levers and the machine will smoothly break to a stop and after 3 seconds the burnish motor will stop. When turning the machine off, turn off the burnish switch and then turn off the key switch.

Operation on Inclines

CAUTION! When the machine is traversing on an incline, up or down, move slowly.

CAUTION! Do not run burnish pad on an incline. The maximum rated climb and descent incline is 6°.

Installing / Changing Burnishing Pad

1. Make sure the Burnish Switch is OFF.
2. Lift on the front of the deck and tilt deck into the pad change position.



3. Remove the center device by turning counter-clockwise and carefully remove the old pad from the Velcro material.

CAUTION! CAREFULLY INSPECT THE PAD HOLDER FOR CRACKS OR DAMAGE! REPLACE IF NECESSARY.

4. Pull center from new pad, align pad on pad holder and secure with centering device by turning clockwise.
5. Press pad firmly onto pad holder face.
6. Lift the front of the shroud and lift the shroud release lever and SLOWLY let the shroud return to the down position.



CAUTION! KEEP HOLD OF THE DECK TO AVOID INJURY!

Dust Bag Removal (20", 24")

The machine has two dust bag options. A re-usable cloth bag and a disposable paper bag. Monitor the dust bag carefully and empty/change as needed. The dust

collection system will not operate effectively when the dust bag is full. Under heavy burnishing conditions the dust bag should be emptied/changed every hour.

1. Turn off the Burnish Motor.
2. Unscrew the knobs holding the dust bag cover to the shroud.



3. Pull the dust bag off the dust tube.



4. Empty/Change dust bag.

Dust Bag (27"/28")

1. Remove the dust bag by working the elastic over the lip of the rubber grommet and pulling toward the rear of the machine.

2. Empty bag by rubbing or gently tapping on sides, in a downward motion, to loosen soil trapped on sides of bag. For heavy soil, turn bag inside out to clean.



3. Check the dust tube for debris and clear needed.

if

4. Reinstall dust bag by working the elastic band over the lip of the rubber grommet.

5. Stretch the dust bag towards rear of machine and orientate with the zipper facing downward.

Caster Parking Brake

The two rear casters are equipped with brakes. To set the brake, push down the "ON" side of the brake lever. To release the brake push down the "OFF" side of the brake lever. The caster breaks should only be used as a parking brake if needed. Before moving the machine make sure both breaks are released.

Pad Pressure Adjustment

The pad pressure is set at the factory for optimal burnish performance in most conditions. If the pad pressure needs to be adjusted, follow the procedure outlined below.

NOTE: Pad pressure adjustments should only be performed by a qualified technician.

1. Turn burnish switch off.
2. Remove back panel.
3. Adjust ball end to increase or decrease pad pressure as shown in diagram.

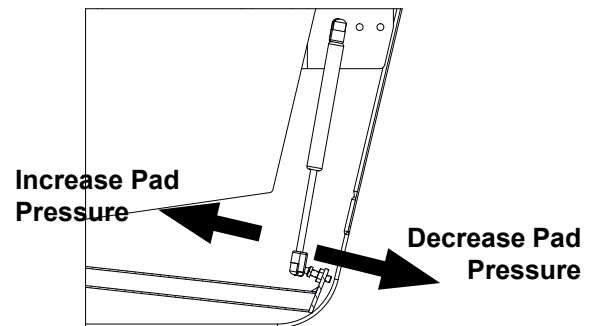

Post Operation Checklist

Turn the machine OFF and perform the following checks:

- Check for wire, string, or twine wrapped around the burnish pad.
- Check for frayed wires or damage.
- Empty the dust collection bag.
- Inspect batteries.
- Plug in on-board battery charger.

Maintenance

Scheduled Maintenance

Operation	Interval						
	Daily	Every 25 Hrs	Every 50 Hrs	Every 100 Hrs	Every 200 Hrs	Every 500 Hrs	Every 1000 Hrs
Empty/Clean Dust Bag	●						
Inspect Pad Holder	●						
Inspect Battery water level (Lead Acid only)			●				
Check wiring harness for fray or cut		●					
Check for loose/missing nuts or screws	●						
Tighten nuts and screws				●			
Check brushes on transaxle motor and burnish motor							●
Lubricate rear casters				●			
Check Burnish motor ampere draw					●		
Replace the gas shock						●	

These items must be performed with the proper tools and training. Contact a Amano Pioneer Eclipse Factory Certified Technician unless you have the proper equipment and mechanical proficiency.

Body & Battery Cover

The body may be cleaned with a damp cloth to remove dust and scuff marks. More stubborn scuff marks on the tank exterior can be removed with a vinyl cleaner

Battery Maintenance

The batteries are deep cycle 12 volt batteries. The lifetime of the batteries is limited by the number of charges the batteries receive. To get the most life from the batteries, charge them when the battery discharge LED (Red) starts to blink (20% charge left). Use only the on-board battery charger supplied to charge the batteries.

Periodically clean the top surface of the batteries and the terminals, and check for loose connections. Use a strong solution of baking soda and water. Brush the solution sparingly over the battery tops, terminals, and cable clamps.

CAUTION! DO NOT ALLOW ANY BAKING SODA SOLUTION TO ENTER THE BATTERIES!

Use a wire brush to clean the terminal posts and cable connectors. After cleaning, apply a coating of clear battery post protectant to the terminals and the cable connectors. Keep the tops of the batteries clean and dry.

To prevent a possible short circuit, keep all metallic objects off the top of the batteries. Replace any worn or damaged wires.

Lead Acid Batteries

Sealed batteries no additional maintenance required.

CAUTION! When working with batteries, always wear eye protection and protective clothing.

CAUTION! Batteries emit hydrogen gas. NO SMOKING!

Never add acid to the batteries, only distilled water. Always keep the battery caps on, except when adding water or taking hydrometer readings.

CAUTION! Never use tap water to fill battery cells. Tap water contains contaminants that will damage the battery. Only use distilled water to fill battery cells.

Check the electrolyte level in each battery cell before and after charging, and after every 50 hours of operation. Do not charge the batteries unless the fluid is slightly above the battery plates. If needed, add just enough distilled water to cover the plates. Never add acid to the batteries.

CAUTION! DO NOT OVERFILL!

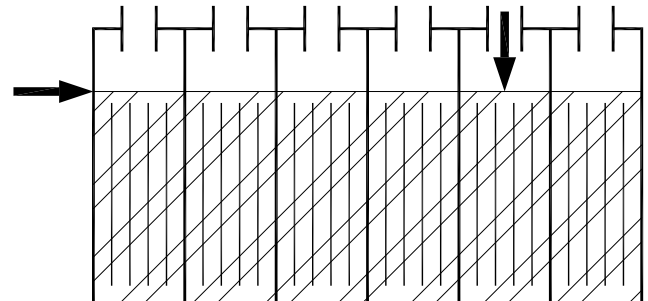

Measuring the specific gravity, using a hydrometer, is a way to determine the charge level and condition of the batteries. If one or more of the battery cells test lower than the other battery cell (0.050 or more), the cell is damaged, shorted, or is about to fail.

CAUTION! Battery damage will occur if the electrolyte level does not cover the battery plates.

CAUTION! Machine and/or battery damage can occur if the electrolyte level is above the bottom of the tube in each cell.

Rear Casters

Each of the two rear casters has two grease fittings. Lubricate each caster with a grease gun every 100 hours of machine operation



Alarm Codes (*Traction Only*)

*Given the following alarm codes, troubleshooting should only be done by a Amano Pioneer Eclipse Factory Certified Technician. A programming handset may be required for troubleshooting.

Number of Flashes	Description	Possible Cause
1 (fast)	Low Battery Voltage	The battery needs charging or there is a bad connection to the battery. Check the connections to the battery. If the connections are good, try charging the battery.
1 (medium)	Handle lever engaged at key on	Disengage the handle lever, key off and key back on to clear
1 (slow)	Machine Time Out	The machine has been left with the key on. Turn the key off and then back on again.
2	Motor Disconnected	The motor has a bad connection. Check all the connections and leads between the motor and the controller.
3	Motor Wiring Trip	The motor has a short circuit to a battery. Check all the connections and leads between the motor and the battery.
6	Inhibit Active	The controller is being inhibited from driving. Check the state of the Inhibit unputs.
7	Throttle Trip	A throttle trip is indicated. Make sure that the throttle is in the rest position before switching on the vehicle.
8	Possible Controller Trip	A possible controller trip is indicated. Make sure that all connections are secure.
9	Solenoid Brake Trip	The parking brakes have a bad connection. Check the parking brake and motor connections. Make sure the controller connections are secure.
10	High Battery Voltage	An excessive voltage has been applied to the controller. This is usually caused by a poor battery connection. Check the battery connections.

Machine Troubleshooting

Problem	Possible Cause	Remedy
Machine will not turn on	Breaker Tripped	Push breaker button to reset
	Incorrect battery connection	Check batteries are wired together correctly via the battery connection diagram, check the Anderson connectors are plugged together
	On-board battery charger plugged in	Unplug the charging cord from the machine
	Key switch failure	Check key switch is functioning and wiring to the key switch is correct
	Failed Fuse	Check the fuse in the in line fuse holder.
Burnish motor will not start	Deck tilted into pad change position	Lower the deck to the burnish position
	Speed control knob turned all the way counter-clockwise (off)	Turn speed control knob clockwise to increase speed
	Burnish switch off	Turn on burnish switch
	Handle levers not engaged	Engage handle levers
	70A breaker tripped	Push 70A breaker to reset.
	Battery lockout	Batteries need to be charged
Red LED Flashing on Dash	Check alarm code reference sheet	Troubleshoot accordingly
Machine exhibits poor burnishing performance	Pad dirty	Remove debris or string/twine from pads; clean pad; replace pad
	Incorrect pad	Use more aggressive burnishing pad
	Pad worn down	Replace pad
Machine exhibits very aggressive burnish performance	Gas Spring faulty	Check ampere draw of burnish motor (should not be above 50 amps); replace gas spring
	Incorrect pad	Use less aggressive burnishing pad
Dust collection not working properly	Dust collection bad, is not collecting dust	Empty dust bag
		Check the dust tube to see if there is an obstruction
	Skirt is not sealing to the floor	Skirt is bent or damaged. Replace if necessary.
		Adjust the skirt to fit tightly against the seal, but still able to move freely
		Check wear edge on bottom of the skirt and replace if necessary

Machine Specifications

<u>Voltage:</u>	36VDC (Qty. 3 - 12VDC Batteries)
<u>Sound Level:</u>	< 70 dB(A)
<u>Vibration:</u>	Less than 2.5 m/s ²
<u>Forward Speed:</u>	3.25 mph (5.23 km/h) <i>Traction Only</i>
<u>Reverse Speed:</u>	1.5 mph (2.4 km/h) <i>Traction Only</i>
<u>Burnish Motor:</u>	2.5 hp (1.86 kw) Permanent Magnet
<u>Transaxle:</u>	.25 hp (186 watts) <i>Traction Only</i>
<u>Battery Charger:</u>	36V 25A On-Board
<u>Wheels:</u>	8 in. (20.3 cm) Solid
<u>Battery:</u>	12VDC Lead Acid 228 Ah (Qty. 3) <i>Weight 126 lbs (57 kg) each - Total Battery Weight 378 lbs (171.5 kg)</i> 12VDC AGM 235 Ah (Qty. 3) <i>Weight 140 lbs (63.5 kg) each - Total Battery Weight 418 lbs (189.6 kg)</i>

20" Machines

Pad Size:	20" (51 cm)
Pad Speed:	2000 RPM
Deck Width:	22" (56 cm)
Length:	49" (124 cm) <i>Head Up</i> 58" (147 cm) <i>Head Down</i>
Height:	45" (114 cm)
Weight:	<i>w/o Batteries</i> 240 lbs (109 kg) <i>Pad-Assist</i> 260 lbs (118 kg) <i>Traction</i>

24" Machines

Pad Size:	24" (61.0 cm)
Pad Speed:	1800 RPM
Deck Width:	26" (66 cm)
Length:	49" (124 cm) <i>Head Up</i> 61" (155 cm) <i>Head Down</i>
Height:	45" (114 cm)
Weight:	<i>w/o Batteries</i> 253 lbs (115 kg) <i>Pad-Assist</i> 272 lbs (123 kg) <i>Traction</i>

27"/28" Machines

Pad Size:	27" or 28" (69 cm or 71 cm)
Pad Speed:	1500 RPM
Deck Width:	29" (74 cm)
Length:	52" (140 cm) <i>Head Up</i> 62" (160 cm) <i>Head Down</i>
Height:	45" (114 cm)
Weight:	<i>w/o Batteries</i> 255 lbs (116 kg) <i>Traction</i>

012015

RF045100

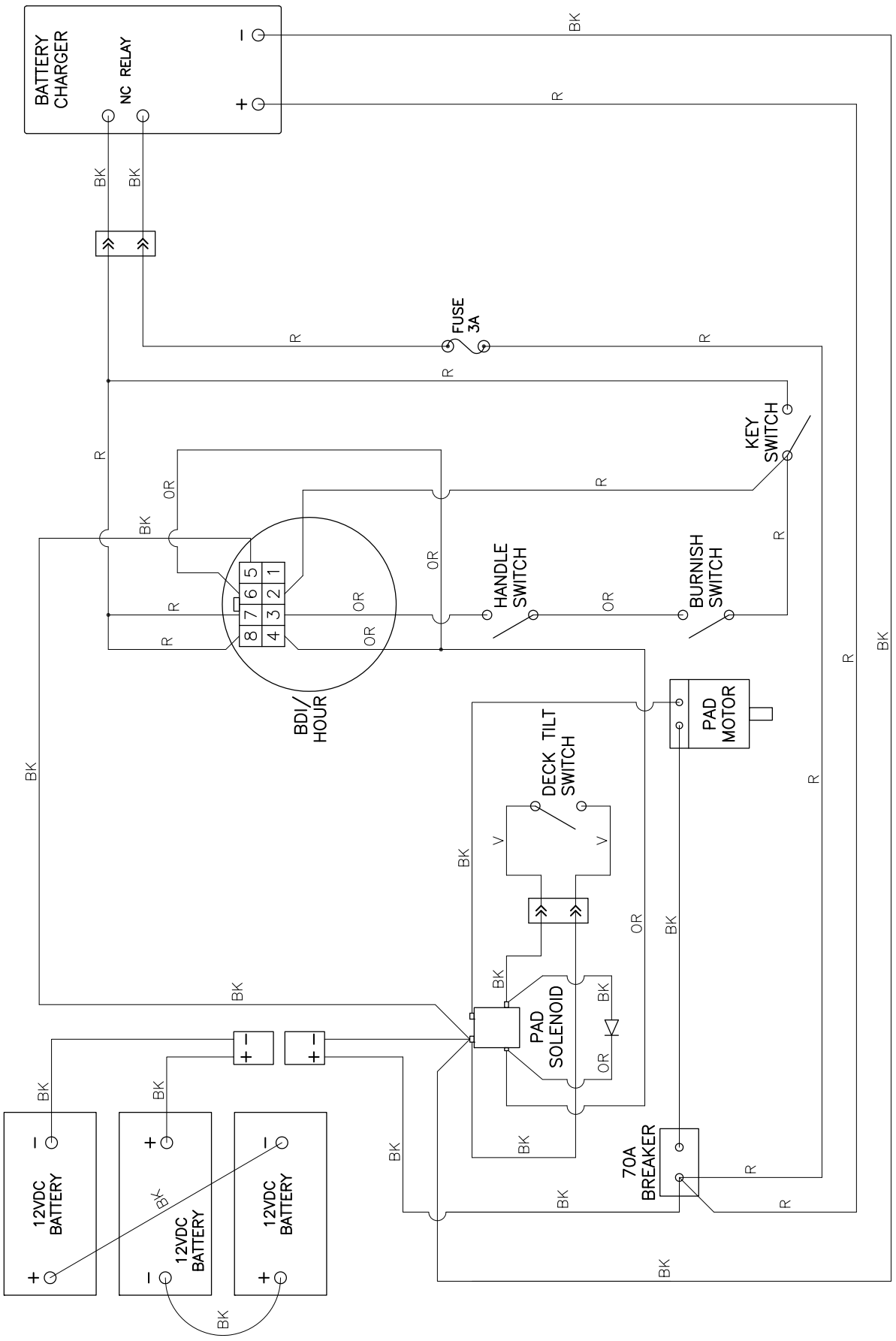

RF045000

041713

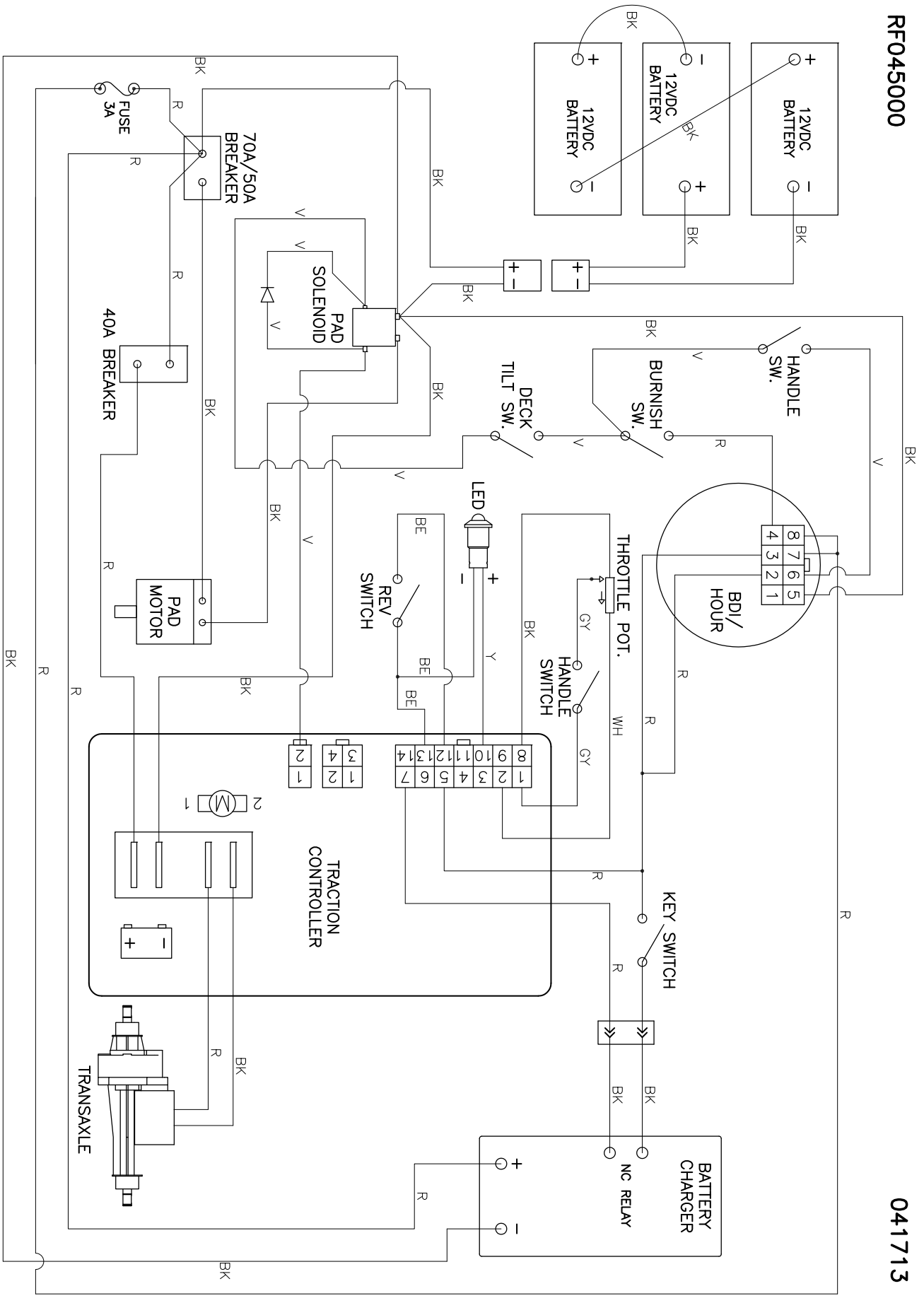

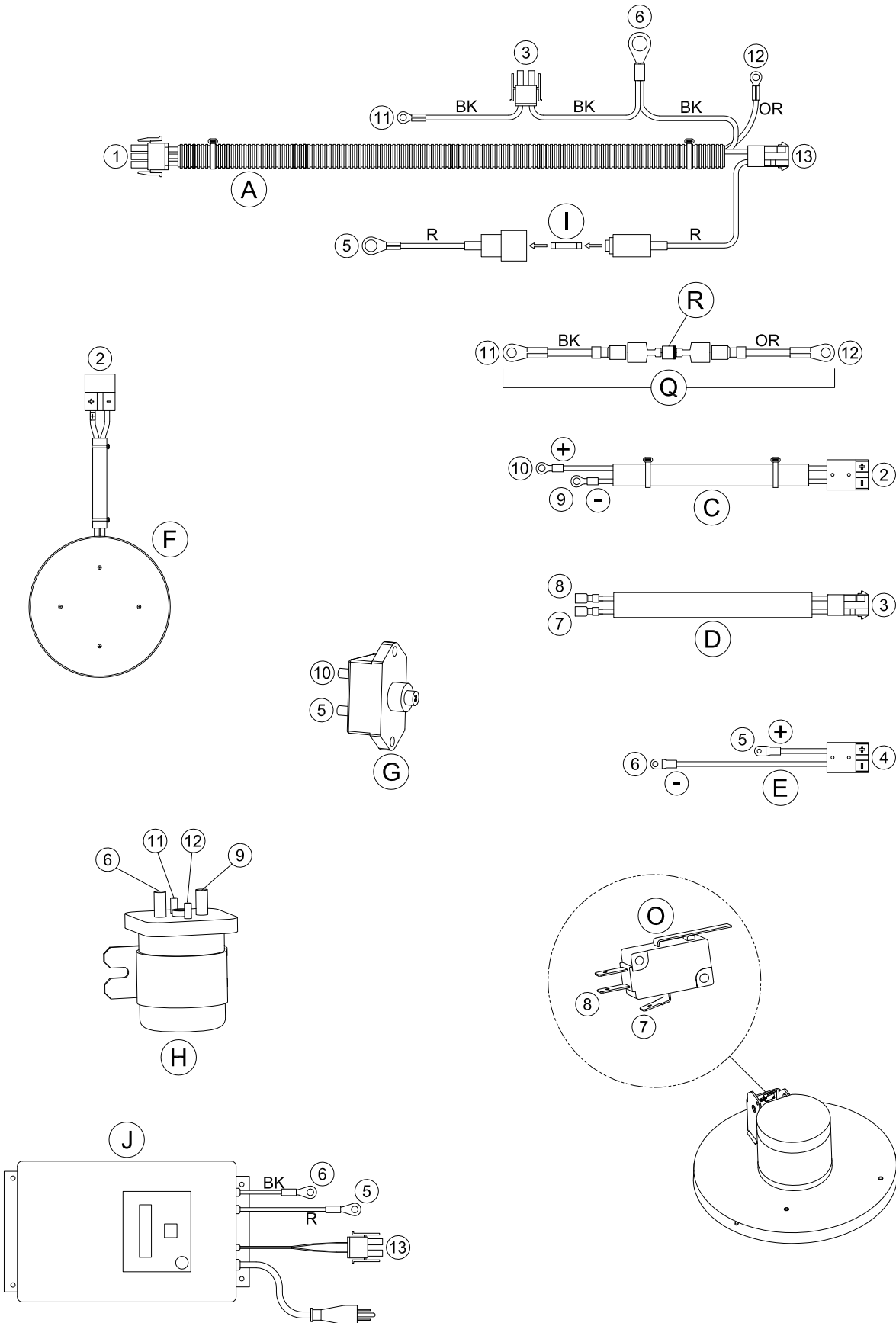

Connections - Pad Assist (Continued)

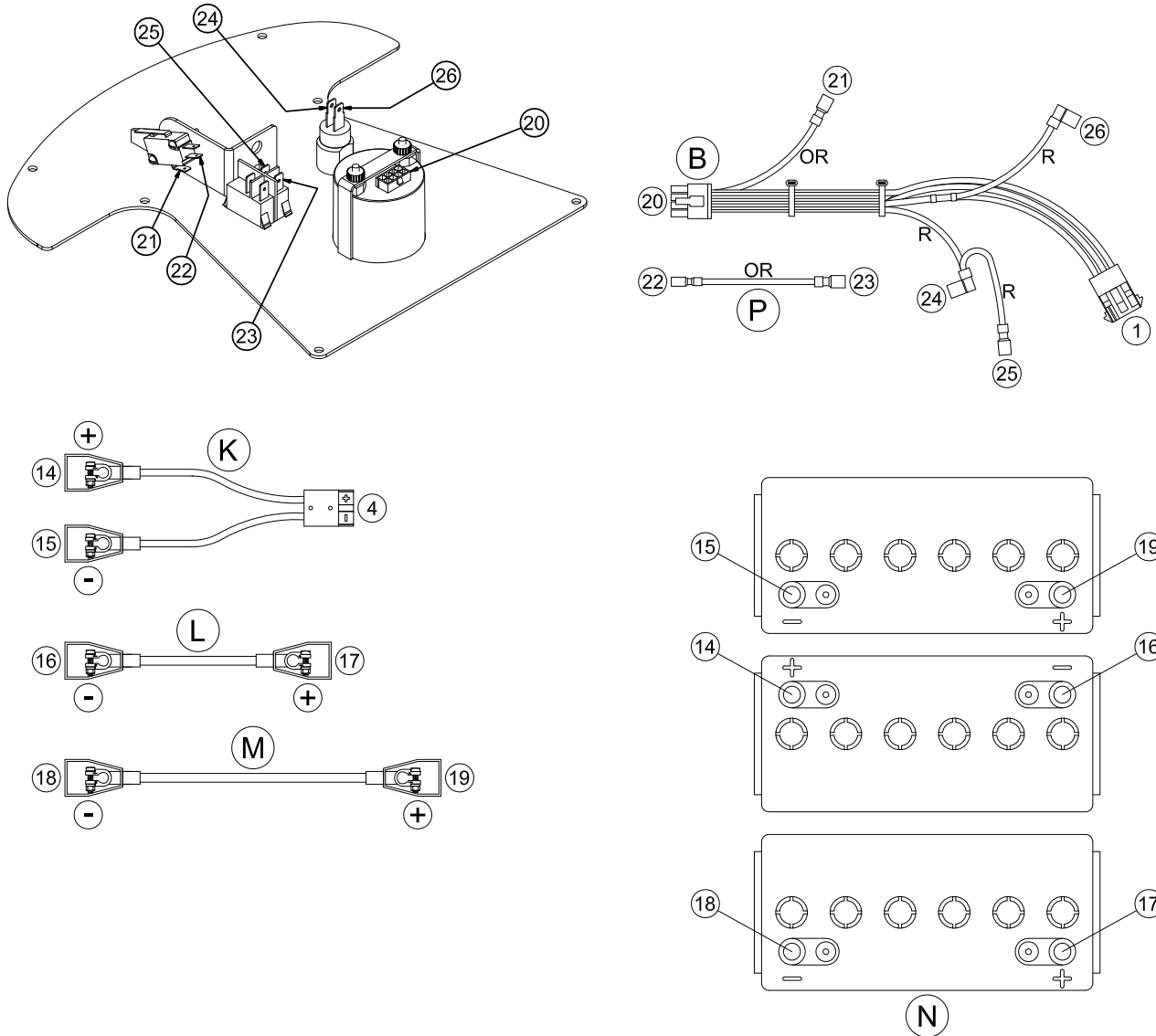

RF044700

032415

Item	Ref. No.	Description	Qty	Item	Ref. No.	Description	Qty
A	MP426500	HARNESS, MAIN, PAD ASSIST	1	K	MP279700	CABLE, BATTERY, w/ PLUG	1
B	MP426700	HARNESS, C.PANEL, PAD ASST.	1	L	MP238200	CABLE, BATTERY, 13.5"	1
C	MP426800	HARNESS, MOTOR, BURNISH	1	M	MP279800	CABLE, BATTERY	1
D	MP427000	HARNESS, SWITCH, TILT	1	N1	MP223500	BATTERY, 12V, LEAD ACID	3
E	MP427200	CABLE, BATTERY, SOLENOID	1	N2	MP413600	BATTERY, 12V, SEALED	3
F1	MP424200	MOTOR, 2000 RPM, ASM. (20")	1	O	MP318400	SWITCH, MICRO, 12V	1
F2	MP434100	MOTOR, 1800 RPM, ASM. (24")	1	P	MP427800	WIRE, SWITCH, 3"	1
G	MP414800	BREAKER, CIRCUIT, 70A	1	Q	MP482400	WIRE, DIODE, ASM.	1
H	MP207000	SOLENOID, 36VDC, SPNO	1	R	MP254600	DIODE, 6A, ASM.	1
I	MP234700	FUSE, 3A, GLASS	1				
J1	SA027500	CHARGER, 110V, 36V, ASM.	1				
J2	SA027600	CHARGER, 220V, 36V, ASM.	1				

Connections - Traction

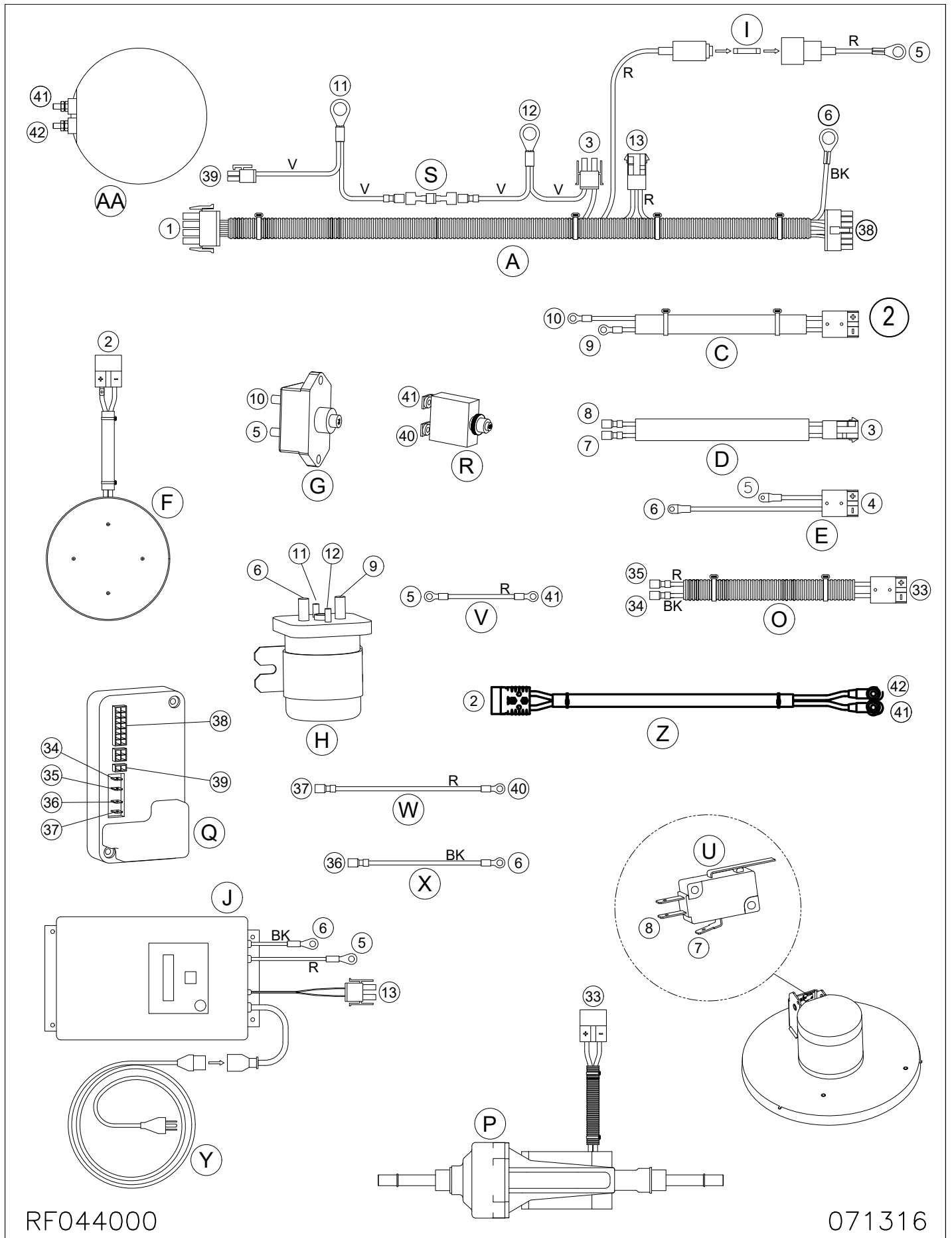

RF044000

071316

Connections - Traction (Continued)

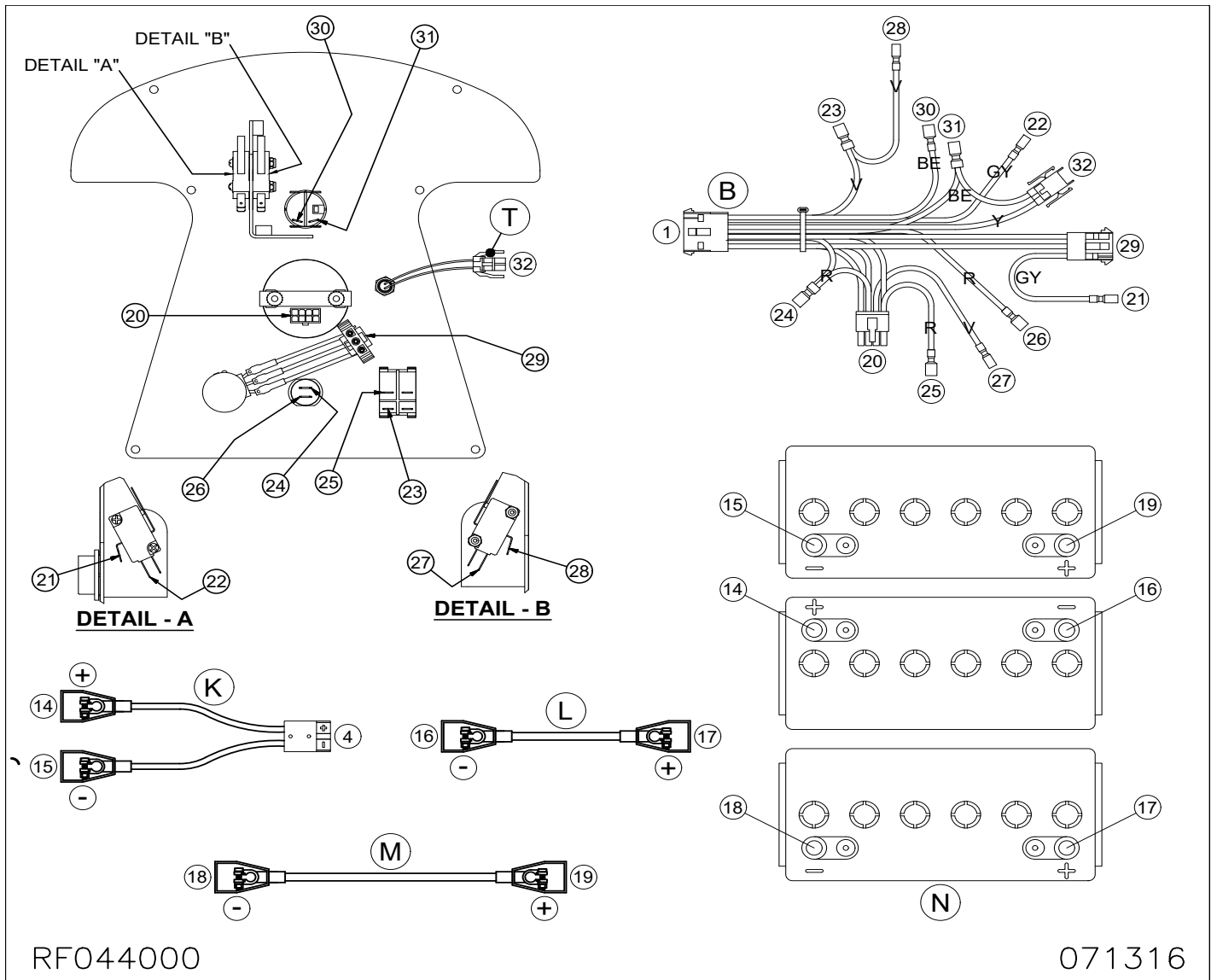

Item	Ref. No.	Description	Qty	Item	Ref. No.	Description	Qty
A	MP432200	HARNES, MAIN, TRACTION	1	O	MP426900	HARNES, WIRING, TR. AXLE	1
B	MP432100	HARNES, C.PANEL, TRACTION	1	P	MP424500	TRANSAXLE, 36V, ASM.	1
C	MP426800	HARNES, MOTOR, BURNISH	1	Q	MP409401	CONTROLLER, TRACTION	1
D	MP427000	HARNES, SWITCH, TILT	1	R	MP414900	BREAKER, CIRCUIT, 40A	1
E	MP427200	CABLE, BATTERY, SOLENOID	1	S	MP254600	DIODE, 6A, ASM.	1
F1	MP424200	MOTOR, 2000 RPM, ASM. (20")	1	T	SA028000	LED, RED, REPLACEMENT	1
F2	MP434100	MOTOR, 1800 RPM, ASM. (24")	1	U	MP318400	SWITCH, MICRO, 12V	1
G	MP414800	BREAKER, CIRCUIT, 70A	1	V	MP427500	WIRE, 10AWG, RED, 3"L	1
H	MP207000	SOLENOID, 36VDC, SPNO	1	W	MP427600	WIRE, 10AWG, REG, 16"L	1
I	MP234700	FUSE, 3A, GLASS	1	X	MP427700	WIRE, 10AWG, BLK, 12"L	1
J1	SA027500	CHARGER, 110V, 36V, ASM.	1	Y1	MP234300	CORD, 14/3, SJT, 6' 7"	1
J2	SA027600	CHARGER, 220V, 36V, ASM.	1	Y2	MP264000	CORD, H05WF3G1.0, 8'2"	1
K	MP279700	CABLE, BATTERY, w/ PLUG	1	Y3	MP411400	CORD, POWER, AUSTRALIAN	1
L	MP238200	CABLE, BATTERY, 13.5"	1	Z	MP527000	HARNES, WIRING, MOTOR, 300BU"	1
M	MP279800	CABLE, BATTERY	1	AA	MP526300	MOTOR, 36VDC, 2.5HP, 1500 RPM	1
N1	MP223500	BATTERY, 12V, LEAD ACID	3				
N2	MP413600	BATTERY, 12V, SEALED	3				

Skirt, Deck & Axle Bracket Assembly

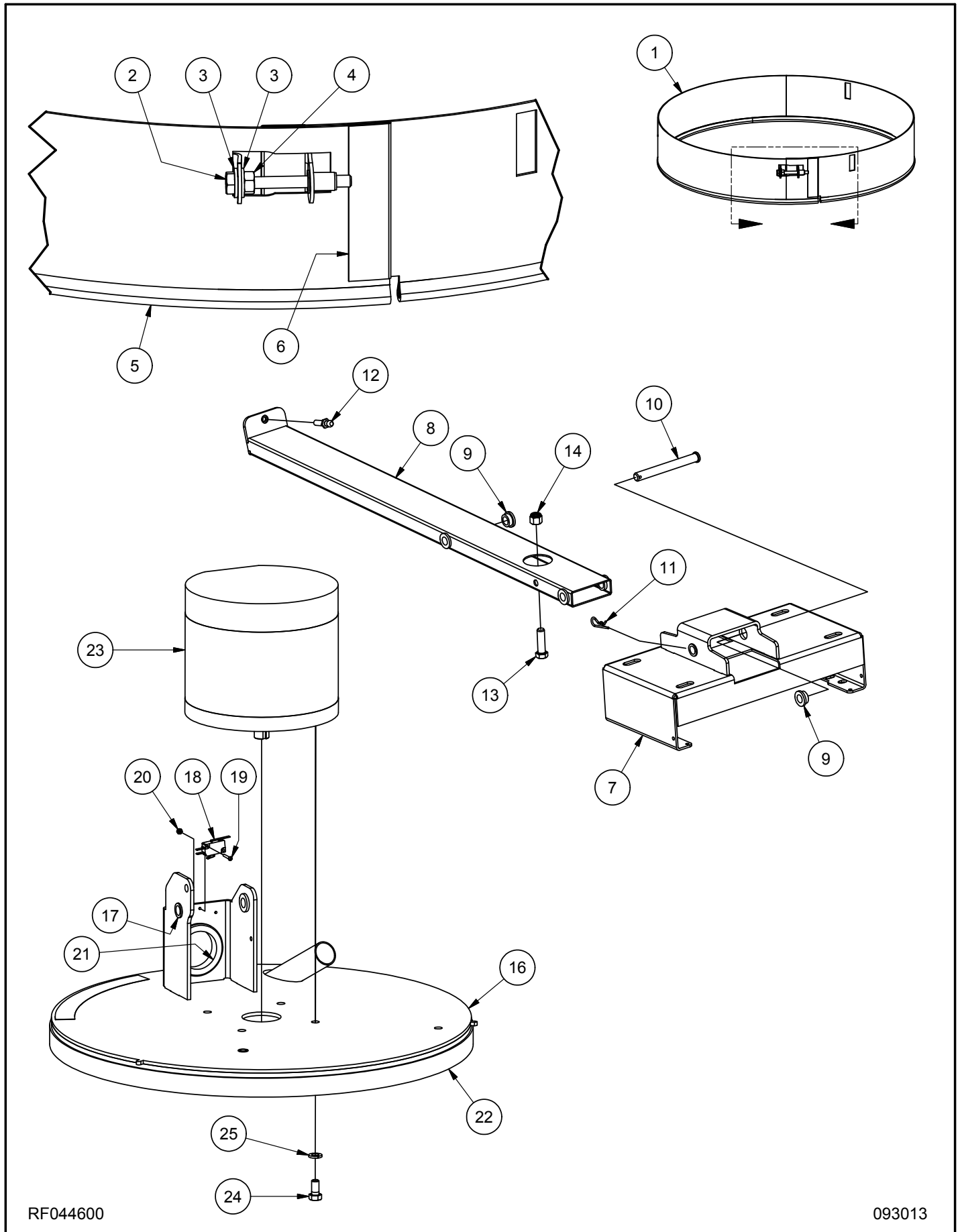

RF044600

093013

Skirt, Deck & Axle Bracket Assembly (continued)

<u>Item</u>	<u>Ref. No.</u>	<u>Description</u>	<u>Qty</u>	<u>Item</u>	<u>Ref. No.</u>	<u>Description</u>	<u>Qty</u>
1A	MP425200	SKIRT, 20", ASM.	1	14A	NB014600	NUT, LOCK, 1/2" (20")	1
1B	MP434200	SKIRT, 24", ASM.	1	14B	NB067700	NUT, LOCK, 7/16" (24")	1
1C	MP526200	SKIRT, 27"/28"	1	15	N/A	N/A	-
2	NB050600	BOLT, HEX, 1/4" X 2-1/2"	1	16A	MP432600	SHROUD, 20", ASM.	1
3	NB3350	WASHER, FLAT, 1/4"	2	16B	MP438800	SHROUD, 24", ASM.	1
4	MX1045	NUT, HEX, 1/4"	1	17	MP237100	BUSHING, FLANGED, 1/2"	2
5A	MP139800	EDGING, WEAR, SKIRT (20")	6 FT	18	MP318400	SWITCH, MICRO, 12V	1
5B	MP139800	EDGING, WEAR, SKIRT (24")	7 FT	19	NB9625	SCREW, #4 X 3/4"	2
5C	MP139800	EDGING, WEAR, SKIRT (27/28")	8 FT	20	NB007000	NUT, LOCK, #4	2
6	MP6600	FELT, VELCRO, BLK, 2"	2 (4")	21	NB043800	GROMMET, 2" ID	1
7	MP423700	BRACKET, AXLE / TRANSAXLE	1	22A	MP415100	FELT, VELCRO, BLK, 1" (20")	6 FT
8	MP423800	TUBE, MOUNT, SHROUD	1	22B	MP415100	FELT, VELCRO, BLK, 1" (24")	7 FT
9	MP237100	BUSHING, FLANGED, 1/2"	6	23A	MP424200	MOTOR, 2000 RPM, ASM. (20")	1
10	NB039704	PIN, CLEVIS, 1/2" X 4-1/2"	1	23B	MP434100	MOTOR, 1800 RPM, ASM. (24")	1
11	NB025600	PIN, PRESTO, 3/32" X 1-5/8"	1	24	NB6851	BOLT, HEX, 3/8" X 3/4"	4
12	MP414300	BALL, STUD, 10MM	1	25	MX1075	WASHER, LOCK, 3/8"	4
13A	NB068900	BOLT, HEX, 1/2" X 1-1/2" (20")	1				
13B	NB068800	BOLT, HEX, 7/16" X 1-1/2" (24")	1				

HEAD, AXLE BRACKET ASSEMBLY (27"/28")

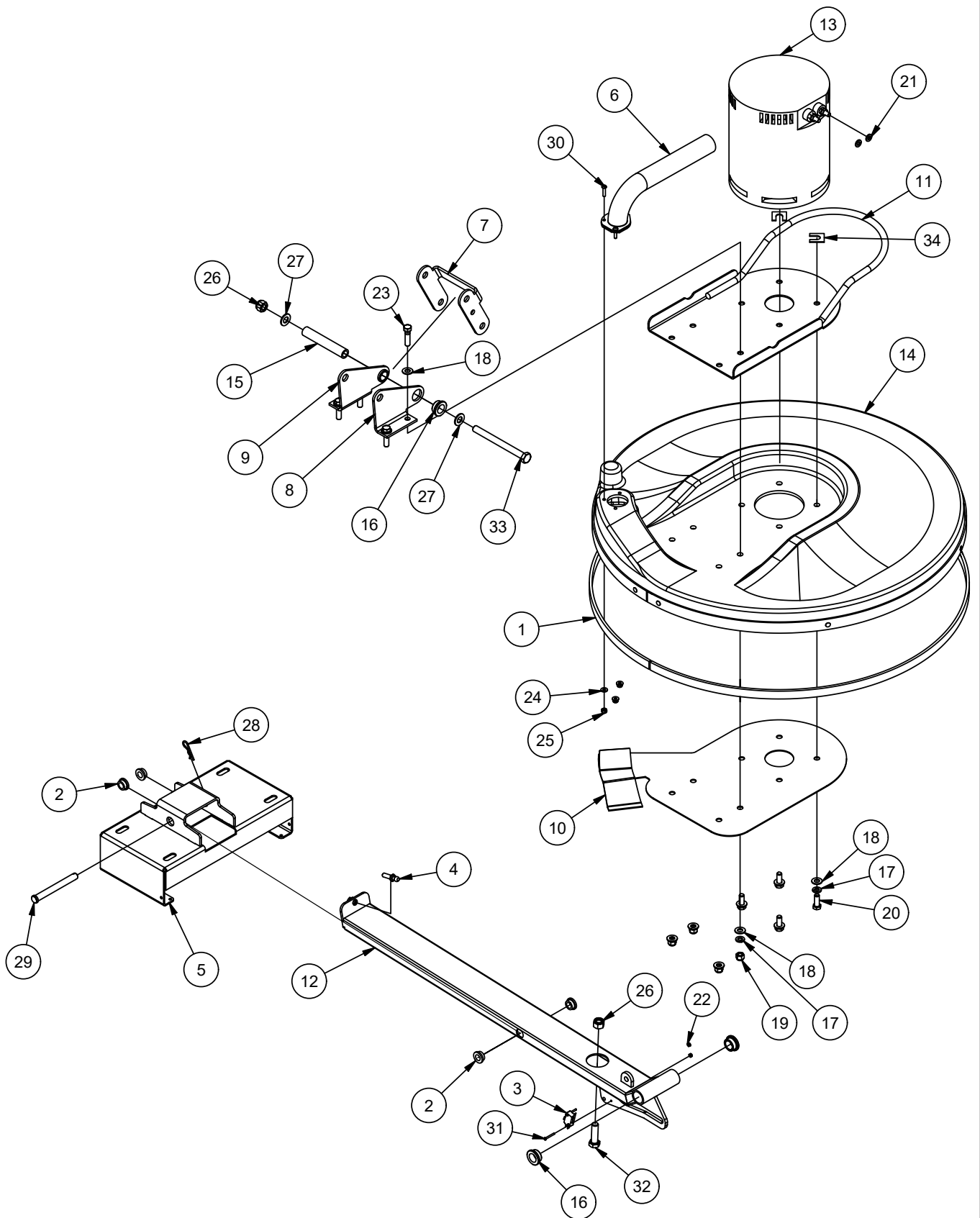

"HEAD, AXLE BRACKET ASSEMBLY (27"/28") continued"

<u>Item</u>	<u>Ref. No.</u>	<u>Description</u>	<u>Qty</u>
1	MP139600_300BU27	FELT, POLYESTER, 28 OZ, BLK	91.86 in
2	MP237100	BUSHING, FLANGED, BRONZE, 1/2I.D. X 3/8L	4
3	MP318400	SWITCH, MICRO, 12V, 15A, 1" LEVER	1
4	MP414300	BALL, STUD, LONG, 10MM	1
5	MP423700	BRACKET, MOUNT, AXLE/ TRANSAXLE, WLDMT.	1
6	MP469500	TUBE, DUST, 90 DEG, WELDMENT	1
7	MP524611	BPLT, BU27 LINK	1
8	MP524711	PIVOT BRACKET SIDE R	1
9	MP524712	PIVOT BRACKET SIDE L	1
10	MP525210	PLT, SHROUD STIFF	1
11	MP525510	WLDMT, MOTOR PLT MOUNT	1
12	MP526000	WLDMT, BU27 SUSPENSION	1
13	MP526300	MOTOR, 36VDC, 2.5HP, 1500 RPM	1
14	MP555000	ASSY, SHROUD, BU27, RET. SKIRT	1
15	MP526700	TUBE, SPACER 3/4OD x 1/2 ID	1
16	MP528001	BUSHING, IGUS, MFI-1216-08	4
17	MX1075	WASHER, LOCK, 3/8"	8
18	MX1080	WASHER, FLAT, 3/8	12
19	NB3267	NUT, LOCK, 3/8", NC	4
20	NB6042	SCREW, CAP, 3/8" X 1"	4
21	NB6111	WASHER, LOCK, 5/16"	2
22	NB007000	NUT, LOCK, NYLON, 4-40	2
23	NB9575	BOLT, HEX, 3/8-16 X 1 1/2	4
24	NB9645	WASHER, FLAT, #10	3
25	NB9735	NUT, LOCK, 10-24, NYLON	3
26	NB014600	NUT, LOCK, 1/2 - 13	2
27	NB018000	WASHER, FLAT, NYLON, 1/2"	2
28	NB025600	PIN, PRESTO, 3/32 X 1 5/8, SS	1
29	NB039704	PIN, CLEVIS	1
30	NB049100	SCREW, BH, 10-24 X 7/8, SS	3
31	NB051000	SCREW, MACH., PAN HD., 4-40 X 1, PHILLIPS	2
32	NB068900	BOLT, HEX, TAP, 1/2-20 X 1-3/4"	1
33	NB074100	SCREW, CAP, HH, 1/2-13 X 5 1/2	1
34	MP197000	SHIM, CAMBER, 1/16"	2

Main Bottom Assembly - Pad Assist

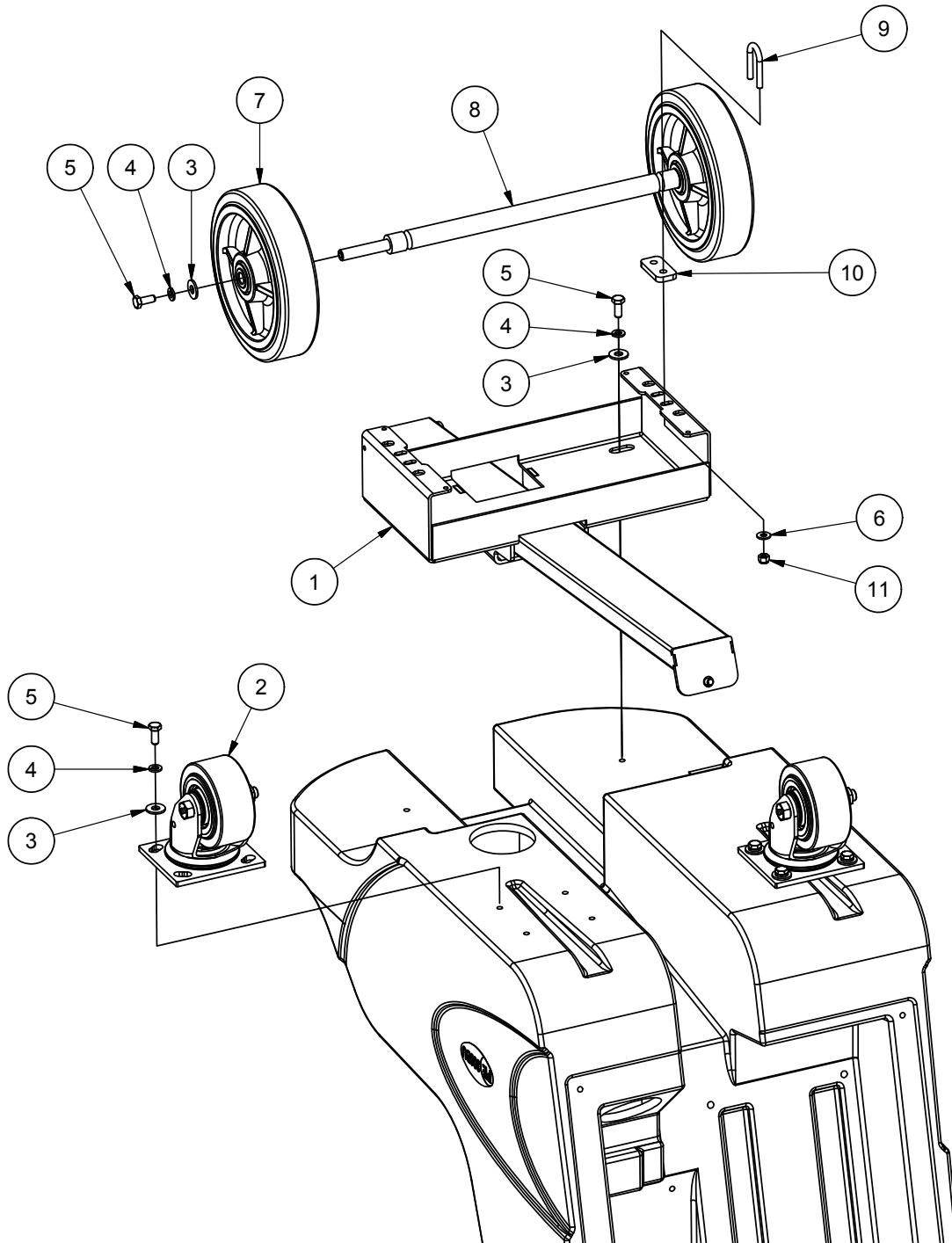

Main Bottom Assembly - Pad-Assist (continued)

<u>Item</u>	<u>Ref. No.</u>	<u>Description</u>	<u>Qty</u>
1A	MP424400	BRACKET, AXLE, ASM. (20")	1
1B	MP440800	BRACKET, AXLE, ASM. (24")	1
2	MP432500	CASTER, 4", w/ BRAKE	2
3	NB9267	WASHER, FLAT, 5/16"	14
4	NB6111	WASHER, LOCK, 5/16"	14
5	NB9745	BOLT, HEX, 5/16" X 3/4"	14
6	NB3350	WASHER, FLAT, 1/4"	4
7	MP409900	WHEEL, 8" X 2"	2
8	MP423500	AXLE	1
9	NB061600	BOLT, U, 1/4"	2
10	MP425301	SPACER, AXLE	2
11	NB3275	NUT, LOCK, 1/4"	4

Main Bottom Assembly - Traction

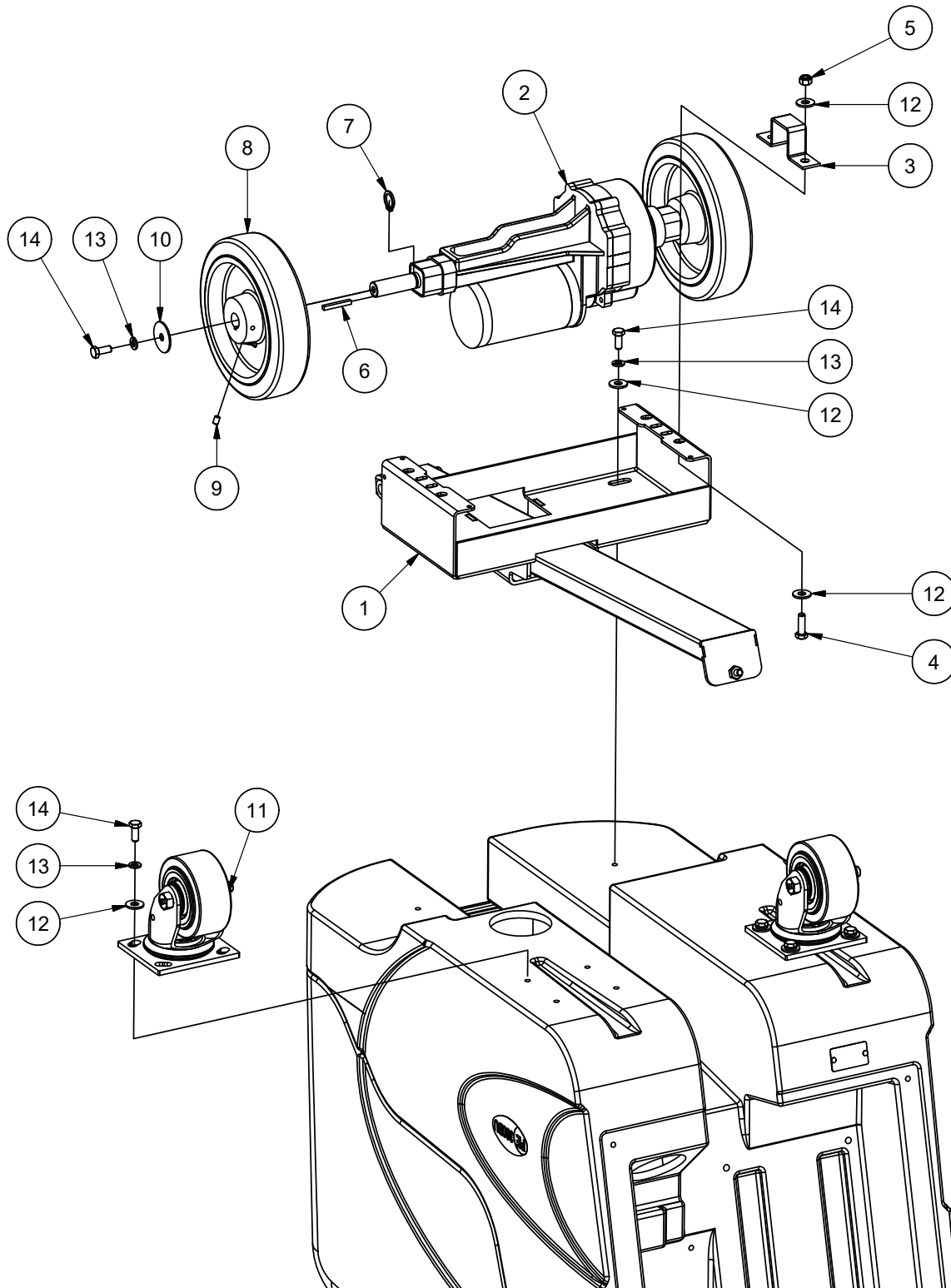

Main Bottom Assembly - Traction (continued)

<u>Item</u>	<u>Ref. No.</u>	<u>Description</u>	<u>Qty</u>
1A	MP424400	BRACKET, AXLE, ASM. (20")	1
1B	MP440800	BRACKET, AXLE, ASM. (24" & 30")	1
2	MP424500	TRANSAXLE, 36 VDC, 3/4" SHAFT, ASM.	1
3	PG001801	BRACKET, TRANSAXLE, PAINTED	2
4	NB6545	SCREW, CAP, HH, 5/16"-18 X 1"	4
5	NB3265	NUT, LOCK, 5/16"-18, NC	4
6	BA003300	KEY, 3/16" X 1-1/2"	2
7	NB018500	RING, RETAINER, 3/4", C-STYLE, HD	2
8	MP409800	WHEEL, 8"X2", DRIVE, 3/4"BORE, GREY	2
9	NB9302	SCREW, SET, 1/4-20 X 3/8, KNURL CUP POINT	4
10	NB9505	WASHER, FLAT, 5/16" X 1-1/2"	2
11	MP411700	CASTER, 4", SWIVEL, 400LB CAP.	2
12	NB9267	WASHER, FLAT, 5/16"	20
13	NB6111	WASHER, LOCK, 5/16"	14
14	NB9745	SCREW, CAP, 5/16"-18 X 3/4"	14

27"/28" Main Bottom Assembly

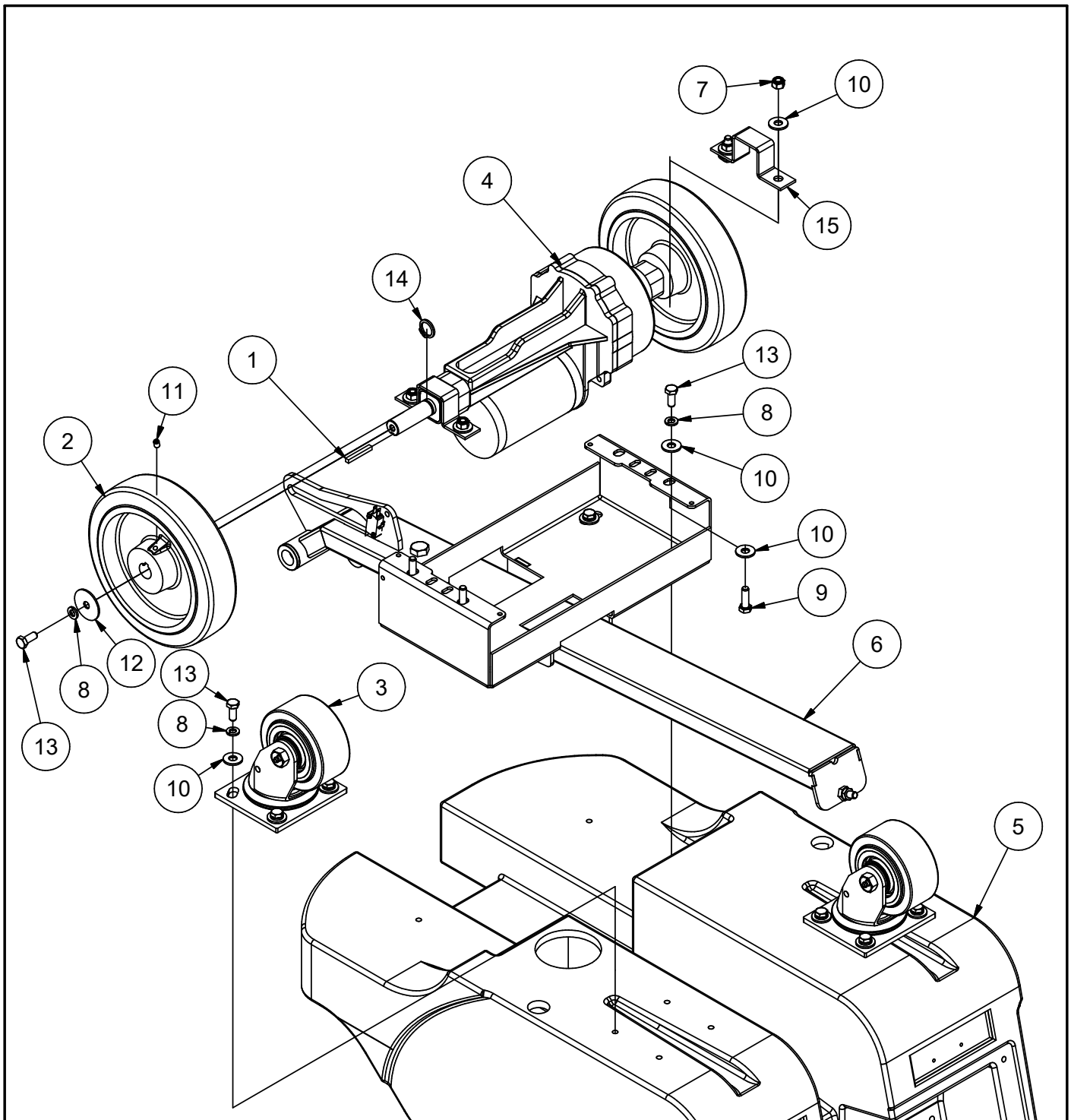

27"/28" Main Bottom Assembly (continued)

<u>Item</u>	<u>Ref. No.</u>	<u>Description</u>	<u>Qty</u>
1	BA003300	KEY, 3/16 X 1.50	2
2	MP409800	WHEEL, 8"X2", DRIVE, 3/4"BORE, GREY	2
3	MP411700	CASTER, 4", SWIVEL, 400 LB CAP.	2
4	MP424500	TRANSAXLE, 36 VDC, 3/4" SHAFT, ASM.	1
5	MP425601	BODY, 300BU, BLACK	1
6	MP526100	ASSY, BU27 SUSPENSION	1
7	NB3265	NUT, LOCK, 5/16"-18, NC	5
8	NB6111	WASHER, LOCK, 5/16"	33
9	NB6545	SCREW, CAP, HH, 5/16"-18 X 1"	4
10	NB9267	WASHER, FLAT, 5/16"	35
11	NB9302	SCREW, SET, 1/4-20 X 3/8, KNUURL CUP POINT	4
12	NB9505	WASHER, FLAT, 5/16" X 1 1/2"	3
13	NB9745	SCREW, CAP, 5/16"-18 X 3/4"	29
14	NB018500	RING, RETAINER, 3/4", C-STYLE, HD	2
15	PG001801	BRACKET, TRANSAXLE, POWERGLIDE, PAINTED	2

Main Rear Assembly

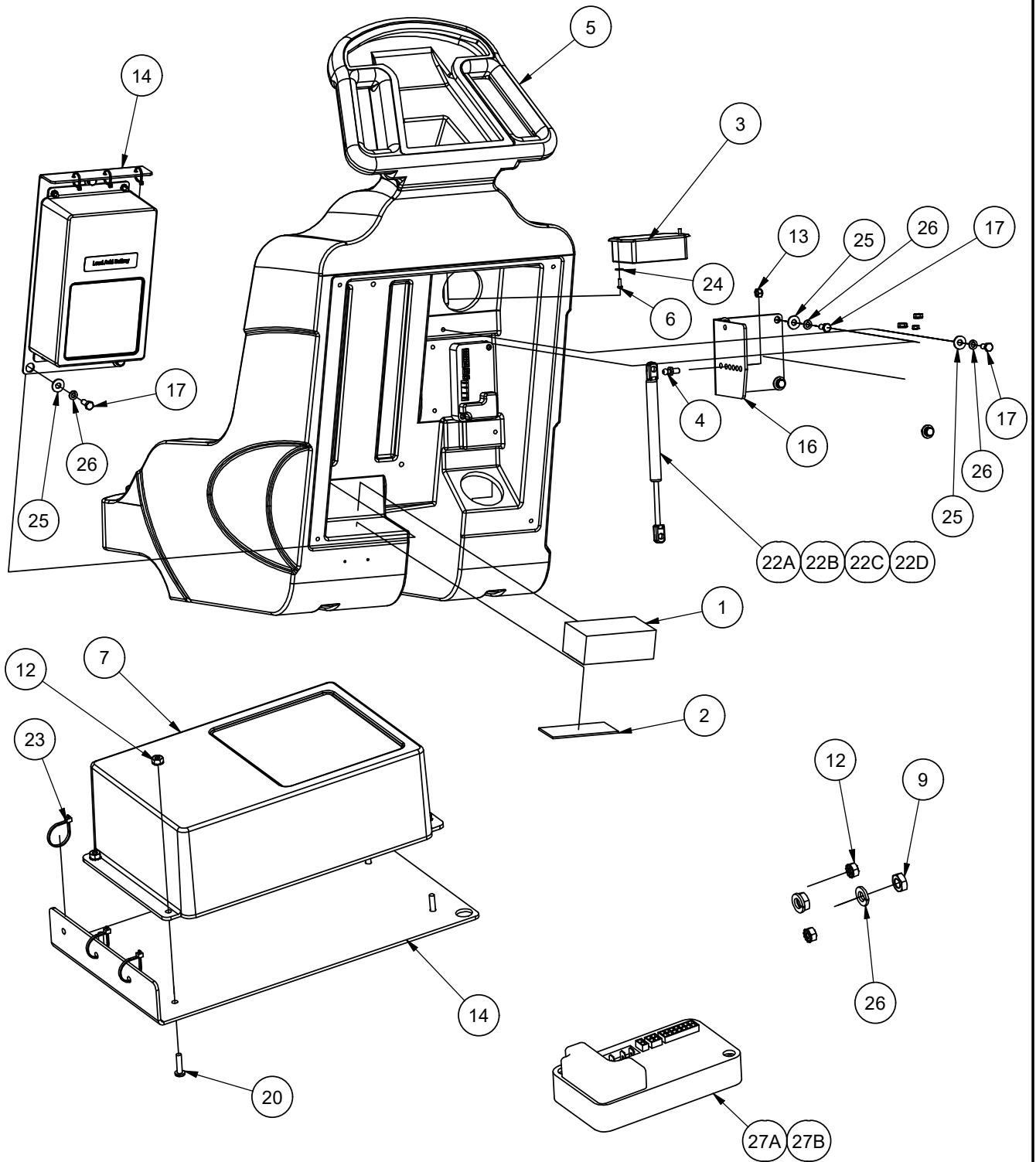

Main Rear Assembly (continued)

<u>Item</u>	<u>Ref. No.</u>	<u>Description</u>	<u>Qty</u>
1	MP530000	ASSY, BU3002728 COUNTER WEIGHT (BU2728 ONLY)	1
2	MP6600	VELCRO, HOOK, 1" w/ADHESIVE (BU2728 ONLY)	5 in.
3	MP530100	ASSY, TELEMATICS CU (OPTIONAL)	1
4	MP206000	BALL, STUD, 10MM	1
5	MP425601	BODY, 300BU, BLACK	1
6	NB007400	BOLT, PHILLIPS PAN HD, #8-32 X 1/2	2
7	MP501100	CHARGER, 36V, 25A, UNIVERSAL	2
9	NB005700	NUT, 5/16-24, JAM	2
12	NB006600	NUT, KEPS, 10-32	6
13	NB3265	NUT, LOCK, 5/16"-18, NC	1
14	MP423101	PLATE, MOUNT, CHARGER	1
16	MP422901	PLATE, MOUNT, SHOCK	1
17	NB9745	SCREW, CAP, 5/16"-18 X 3/4"	9
20	NB040400	SCREW, PAN HEAD, #10-32 UNF, X 3/4	4
22A	MP415200	SPRING, GAS (20")	1
22B	MP434500	SPRING, GAS (24") DOMESTIC	1
22D	MP505500	SPRING, GAS, (27"/28") (24" AUSTRALIAN)	1
23	NB6035	TIE, NYLON, 1/8" X 4", BLK	3
24	NB9720	WASHER, FLAT, #8	2
25	NB9267	WASHER, FLAT, 5/16"	9
26	NB6111	WASHER, LOCK, 5/16"	11
27A	MP409402	CONTROLLER, TRACTION, 36V, BU2728"	1
27B	MP409401	CONTROLLER, TRACTION, 36V, PROGRAMMED	1

Main Top Assembly

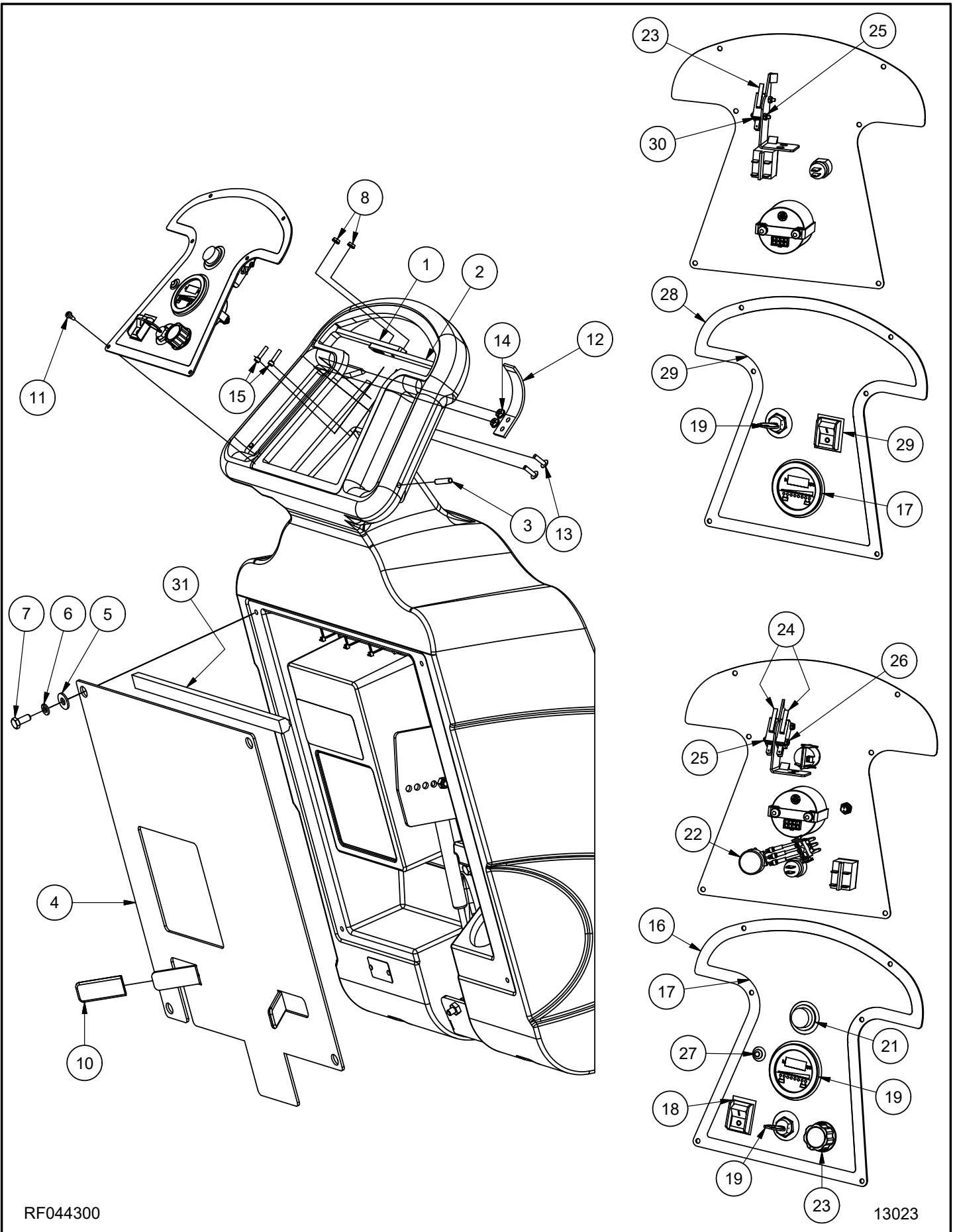

Main Top Assembly (continued)

<u>Item</u>	<u>Part Number</u>	<u>Description</u>	<u>Qty</u>
1	MP529610	WLDMT, LEVER, 300BU L	1
2	MP529710	WLDMT, LEVER, 300BU R	1
3	NB6390	PIN, ROLL, 1/4 X 1 1/8	2
4	MP431401	PLATE, COVER, REAR, W/ SLOT	1
5	NB9267	WASHER, FLAT, 5/16"	35
6	NB6111	WASHER, LOCK, 5/16"	33
7	NB9745	SCREW, CAP, 5/16"-18 X 3/4"	30
8	NB9710	NUT, KEPS, 8-32, ZINC	2
10	MP077400	COVER, TENSION, SPRING	2
11	NB043600	SCREW, PH, HI-LO, #8 x 3/8"	6
12	MP432900	SPRING, HANDLE LEVER, 1/8"X1"X4"	1
13	MX1025	SCREW, PAN HD, 10-24 X 3/4	2
14	NB9510	NUT, SPIN LOCK, 10-24	2
15	NB084200	SCREW, 8-32 X 3/4, SOCKET HD	2
16	MP431600	PANEL, CONTROL, TRACTION	1
17	MP498600	DECAL, CONTROL PANEL, TRACTION	1
18	MP494800	SWITCH, ROCKER, DPST, W/GUARD	1
19	MP414501	METER, HOUR/ BATTERY IND.	1
20A	MP411300	SWITCH, KEY, 36V	1
20B	KC4834001	REPLACEMENT KEY (NOT SHOWN)	1
21	MP505600	SWITCH, PUSH, 250V (TRAC. ONLY)	1
22	PG016400	POTENTIOMETER, ASM. (TRAC. ONLY)	1
23	MP418000	KNOB, PHENOLIC (TRAC. ONLY)	1
24	MP318400	SWITCH, MICRO, 12V	1
25	NB051000	SCREW, MACH., PAN HD., 4-40 X 1	2
26	NB007000	NUT, LOCK, NYLON, 4-40	4
27	SA028000	LED, RED, 36V, REPLACEMENT, KIT	1
28	MP424100	PANEL, CONTROL, PAD ASSIST	1
29	MP498700	DECAL, CONTROL PANEL	1
30	NB9625	SCREW, 4-40 X 3/4"	2
31	MP038300	MOLDING, TRIM	16"

Main Front Assembly

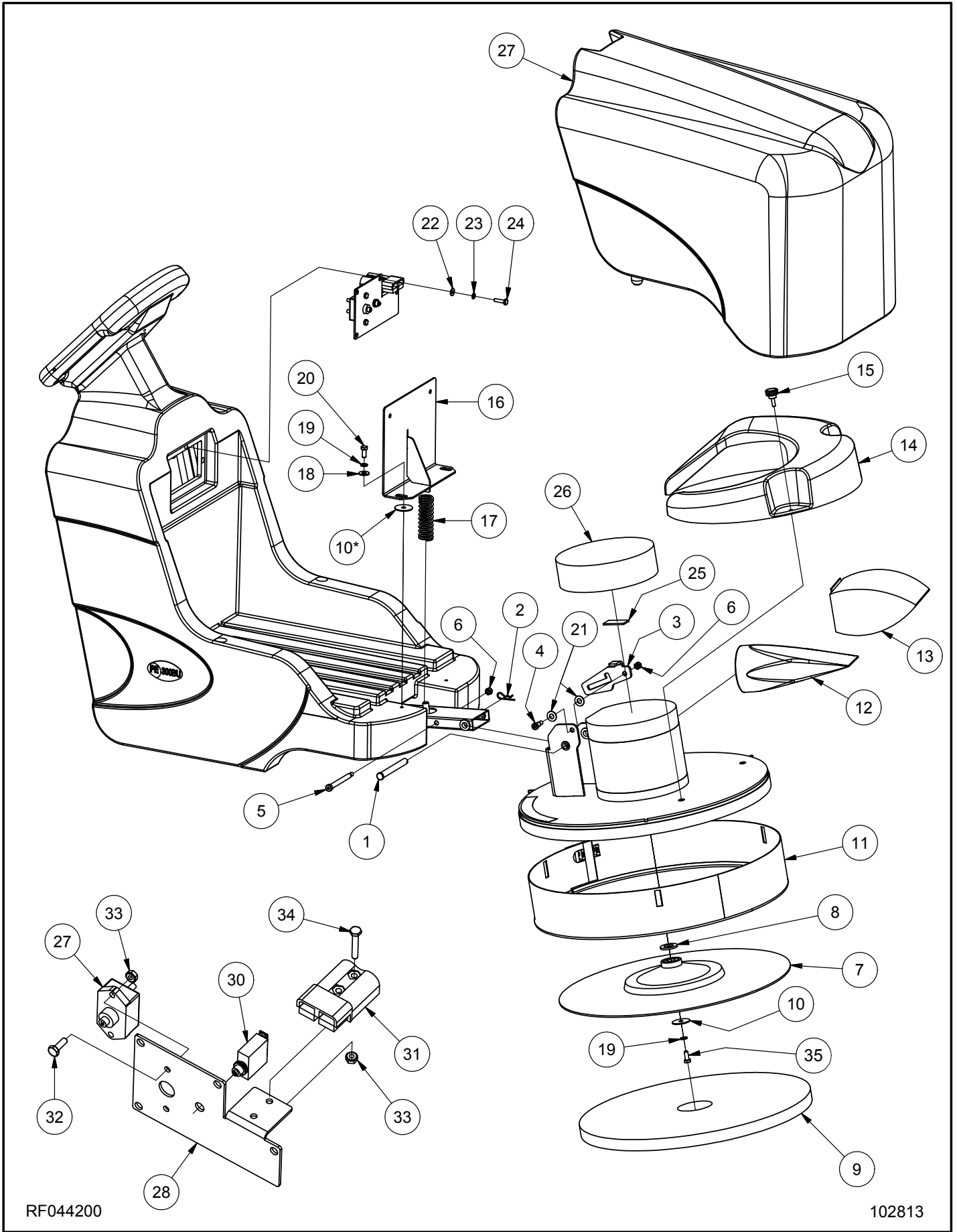

RF044200

102813

Main Front Assembly (continued)

<u>Item</u>	<u>Ref. No.</u>	<u>Description</u>	<u>Qty</u>	<u>Item</u>	<u>Ref. No.</u>	<u>Description</u>	<u>Qty</u>
1	NB039704	PIN, CLEVIS, 1/2" X 4-1/2"	1	18	NB9267	WASHER, FLAT, 5/16"	2
2	NB025600	PIN, PRESTO, 3/32" X 1-5/8"	1	19	NB6111	WASHER, LOCK, 5/16"	3
3	MP423301	LATCH, TILT	1	20	NB9745	BOLT, HEX, 5/16" X 3/4"	3
4	NB026200	BOLT, SHLD, 3/8" X 1/2"	1	21	NB025200	WASHER, FLAT, 3/8"	2
5	NB038600	BOLT, SHLD, 3/8" X 3-1/2"	1	22	NB3350	WASHER, FLAT, 1/4"	4
6	NB3265	NUT, LOCK, 5/16"	2	23	NB6110	WASHER, LOCK, 1/4"	4
7A	MP414000	PAD HOLDER, 20"	1	24	NB6530	BOLT, HEX, 1/4" X 1"	4
7B	MP435000	PAD HOLDER, 24"	1	25	MP8300	HOOK, VELCRO, 1"	2"
7C	MP432400	RETAINER, PAD (NOT SHOWN)	1	26	MP464800	FILTER, DUST, MOTOR	1
8	NB018600	WASHER, FLAT, 3/4"	1	27	MP432700	COVER, BATTERY, ASM.	1
9	N/A	N/A	-	28	MP422801	PLATE, MOUNT, PLUG	1
10	NB9505	WASHER, FLAT, 5/16" X 1-1/2"	1	29	MP414800	BREAKER, CIRCUIT, 70A	1
11A	MP425200	SKIRT, 20", ASM.	1	30	MP414900	BREAKER, CIRCUIT, 40A (TRAC.)	1
11B	MP434200	SKIRT, 24", ASM.	1	31	MP427200	CABLE, BATTERY, SOLENOID	1
12	MP414100	BAG, DUST, CLOTH	1	32	NB6535	BOLT, HEX, 1/4" X 3/4"	2
13	MP414200	BAG, DUST, PAPER	1	33	NB9845	NUT, KEPS, 1/4"	4
14	MP431300	COVER, BAG, DUST	1	34	NB9000	BOLT, HEX, 1/4" X 1-1/2"	2
15	MP155600	KNOB, 1/4" X 3/4"	2	35	NB9500	BOLT, HEX, 5/16" X 1-1/4" UNF	1
16	MP423900	RETAINER, BATTERY	1				
17A	MP415300	SPRING, COMP., .90" ID (20")	1				
17B	MP434400	SPRING, COMP., .81" ID (24")	1				

27"/28" Main Front Assembly

27"/28" Main Front Assembly

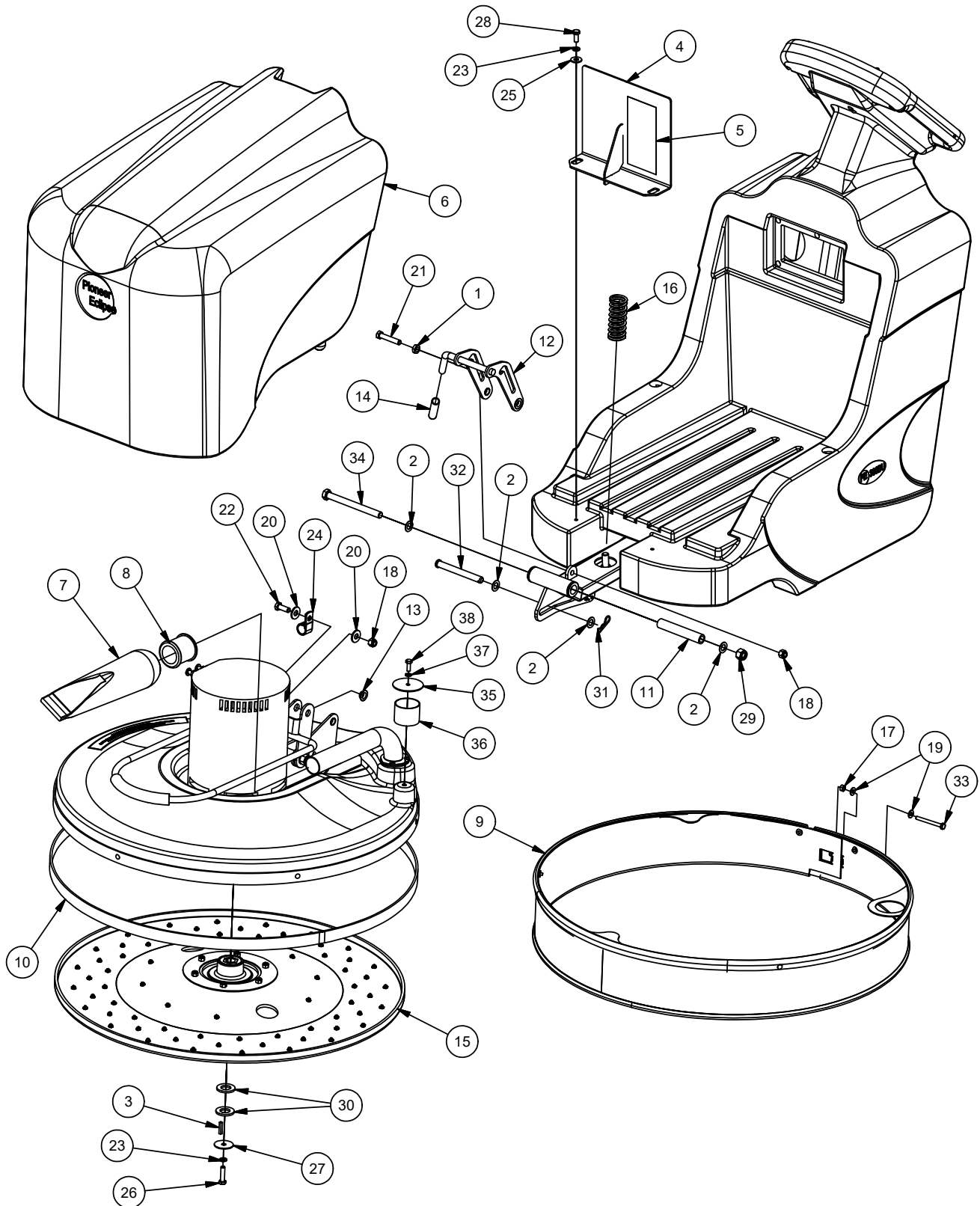

RF090900

102422

27"/28" Main Front Assembly (continued)

<u>Item</u>	<u>Ref. No.</u>	<u>Description</u>	<u>Qty</u>
1	920148	NUT, 3/8-16 JAM	1
2	980673	WASHER FLT 1/2 ID X 7/8 OD	4
3	BA003200	KEY, 3/16 X 1	1
4	MP423900	RETAINER, BATTERY, WELDMENT	1
5	MP429600	DECAL, BATTERY CONN., 36V	1
6	MP432700	COVER, BATTERY, 300BU, ASM.	1
7	MP469300	BAG, DUST, 12"	1
8	MP469400	GROMMET, 1.5 ID X 2.0 OD, X 1.84 W	1
9	MP554700	ASSY, SKIRT, RETAINED	1
10	MP554800	ASSY, BU2728 HEAD, RET. SKIRT	1
11	MP526700	TUBE, SPACER 3/4OD x 1/2 ID	1
12	MP527810	WLDMT, 300BU27 LATCH	1
13	MP528002	BUSHING, IGUS, JFI-0809-04	4
14	MP528700	GRIP, YELLOW, 1/2" ID x 3.5" LONG	4
15	MP529400	ASSY, 2728 PAD HOLDER	1
16	MP530500	SPRING, COMP., .1.086 ID X 1.46 OD X 3.5" L.	1
17	MX1045	NUT, HEX, 1/4-20	1
18	NB3267	NUT, LOCK, 3/8", NC	2
19	NB3350	WASHER, FLAT, 1/4", CZ	1
20	NB3450	WASHER, FLAT, 3/8"	2
21	NB4791	SCREW, CAP, 3/8" X 2"	1
22	NB6042	SCREW, CAP, 3/8" X 1"	1
23	NB6111	WASHER, LOCK, 5/16"	3
24	NB8130	CLAMP, 3/4" ID, RETAINER	1
25	NB9267	WASHER, FLAT, 5/16"	2
26	NB9500	SCREW, CAP, 5/16-24 X 1 1/4	1
27	NB9505	WASHER, FLAT, 5/16" X 1 1/2"	1
28	NB9745	SCREW, CAP, 5/16"-18 X 3/4"	2
29	NB014600	NUT, LOCK, 1/2 - 13	1
30	NB018600	WASHER, FLAT, 3/4"	2
31	NB025600	PIN, PRESTO, 3/32 X 1 5/8, SS	1
32	NB039704	PIN, CLEVIS	1
33	NB050600	BOLT, HEX, TAP, 1/4-20 x 2-1/2"	1
34	NB074100	SCREW, CAP, HH, 1/2-13 X 5 1/2	1
35	MP554401	PLATE, SKIRT RETAINER	1
36	MP554200	TUBE, SKIRT RETAINER	1
37	980657	WASHER, LOCK 1/4"	1
38	85806A	SCREW 1/4-20 X 3/4 HX SZ CAP	1

27"/28" Main Front Assembly (continued)

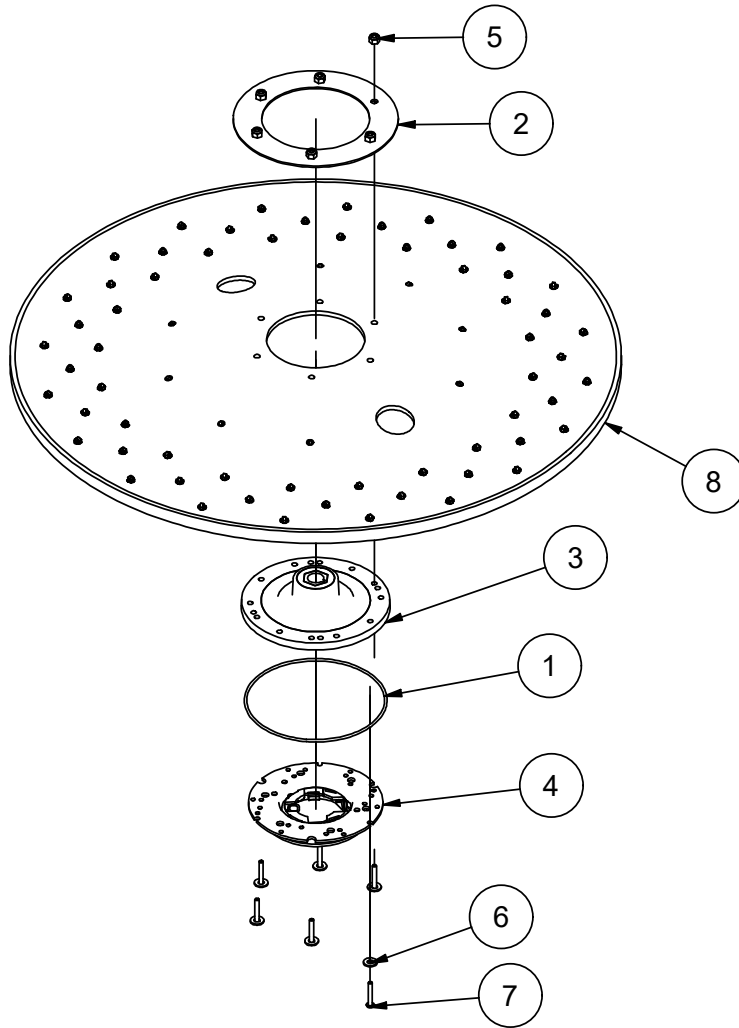

Parts List			
ITEM	QTY	PART NUMBER	DESCRIPTION
1	1	MP066300	RING, SPACER, CENTER LOK II
2	1	MP196300	RING, RELIEF, STRESS, LARGE, PADHOLDER
3	1	MP211500	FLEXI-DISC, W/O LIP, .75" BORE
4	1	MP288600	RETAINER, PAD, CENTER-LOK IV (SNAP-IN)
5	6	NB3275	NUT, LOCK, 1/4"
6	6	NB3350	WASHER, FLAT, 1/4", CZ
7	6	NB9319	SCREW, BH, 1/4-20 X 1 1/4"
8	1	SA004000	PADHOLDER, 28", W/STUDS ONLY



Amano Pioneer Eclipse Corporation

1 Eclipse Rd ● PO Box 909
Sparta, North Carolina 28675 ● USA
www.pioneereclipse.com

+1-336-372-8080
1-800-367-3550
Fax +1-336-372-2913

EC Machinery Directive 2006/42/EC,
EC Restriction of Hazardous Substances Directive (2011/65/EU)
Harmonized Standards Applied: EN 12100-1, EN12100-2