



Propane Stripping Machine
PE440ST
Operator's Manual



Instructions For Use

Failure to read and understand this manual before operating this machine or performing service on this machine may result in injury to the operator or nearby personnel or result in damage to the machine or nearby property. Each operator must be trained in the operation of this machine before being allowed to use it. Contact Amano Pioneer Eclipse Customer Service at 1-800-367-3550 or +1-336-372-8080 or an authorized Amano Pioneer Eclipse Distributor to inquire about training or to request a replacement manual.

NOTICE

Proper maintenance is necessary with all propane powered floor machines. Following the scheduled maintenance procedures found in your operation manual will provide many years of uninterrupted service.



In addition to the scheduled maintenance procedures listed it is recommended to have your machine serviced by certified service personnel every three months. This service should include an emissions check.

DANGER! For your safety, if you smell propane:

1. Extinguish any open flame.
2. Open window.
3. Do not touch electrical switches.
4. Immediately call your propane supplier.

DANGER! Do not store or use gasoline or other flammable vapors and liquids in the vicinity of this or any other appliance.

Record This Important Information

Date of Purchase _____

Purchased From _____

Address _____

City _____ State _____ Zip _____

Phone _____ Contact _____

Machine Model _____

Machine Serial Number _____

Important Phone Numbers

Medical Emergency _____

Police _____

Fire Department _____

In this Operation Manual you will find three statements that you must read and observe to ensure safe operation of this machine.

DANGER! indicates that the possibility of severe bodily injury or death can occur if DANGER! statements are ignored. Read and observe all DANGER! statements included in the Operation Manual and attached to the machine.

WARNING! indicates that the possibility of bodily injury to the operator and other people can occur if WARNING! statements are ignored. Read and observe all WARNING! statements included in the Operation Manual and attached to the machine.

CAUTION! indicates that the possibility of damage to the machine or other property can occur if CAUTION! statements are ignored. Read and observe all CAUTION! statements included in the Operation Manual and attached to the machine.

Table of Contents

Quick Reference Specifications.....	6	Oil Filter Replacement.....	24
Safety Precautions.....	7	Spark Plug Inspection and Replacement.....	24
Refueling and Storage of Fuel Cylinders.....	9	Hood Removal.....	24
Operator Responsibility.....	9	Air Filter Inspection and Replacement.....	24
Canadian Safety Requirements.....	10	Engine Dust Filter.....	25
Test for Operator-Ear Sound Pressure Level.....	11	Valve Clearance & Re-torque Heads.....	25
Test for Hand Arm Vibration.....	11	Valve Seating.....	25
Machine Preparation.....	12	Head Bolt Maintenance.....	25
Unpacking the Machine.....	12	Cooling Fin Maintenance.....	25
Filling the LP Cylinder.....	12	Inspect Fuel Hose and Connections.....	25
Installing the LP Cylinder.....	12	Inspect Brushes and Pad Holders.....	25
Machine Components.....	13	Belt Maintenance.....	26
Controls and Instruments.....	13	Belt Replacement.....	26
Engine Ignition Switch.....	14	Gearbox Maintenance.....	26
Hour Meter/Tachometer.....	14	Tire Maintenance.....	26
Bail Throttle.....	14	Battery Maintenance.....	27
Fuse.....	14	Machine Storage.....	27
SafeSense Emissions Monitoring.....	15	Repacking the Machine.....	27
Rok-Bak & Pad Change.....	16	Transporting the Machine.....	27
SafeStop (optional).....	16	Machine Specifications.....	28
Pad / Brush Change.....	17	Parts Manual.....	29
Handle Adjustment.....	17	Electrical Schematic (with SafeSense).....	30
Transport Cart.....	18	Electrical Schematic (without SafeSense).....	32
How the Machine Works.....	18	Connections (with SafeSense).....	34
Pre-Operation Checklist.....	18	Connections (without SafeSense).....	38
LP Fuel Cylinder.....	19	Engine Assembly.....	40
Installing the LP Fuel Cylinder.....	19	Frame Assembly.....	42
Starting the Machine.....	20	Bulkhead Assembly.....	44
Idling and Stopping the Machine.....	20	Main Assembly.....	46
Stripping.....	20	Main Assembly (Deck).....	48
Machine Troubleshooting.....	21	Regulator, Handle, & Hood Assembly.....	50
Maintenance.....	22	Transport Cart Assembly.....	52
Scheduled Maintenance Chart.....	22	Small Off Road Engine Certification Warranty.....	54
Oil Level Inspection.....	23	Safety Awareness Form.....	55
Oil Change.....	23		

Quick Reference Specifications:

Capacities:

- Engine Oil:
 - Filter not removed: 1.6qt. (1.5L)
 - Filter removed: 1.8qt. (1.7L)
 - Engine Oil Type: SAE30 with API Service Classification SH or SJ

Routine Maintenance Parts:

- Engine Dust Filter (Hood): MP373400
- Engine Oil Filter: KA490657007
- Engine Primary Air Filter (Paper Element): KA110130752
- Engine Air Pre-Cleaner (Foam Element): KA110137046
- Spark Plug: KA920702112
- Battery: MP362200
- Drive Belt: MP402100 (21"/38")
- Fuses: SS2570 (20A)
MP043000 (7.5A)
- LP Cylinder: MP105900 (Steel)
- Brushes / Pad Holders:
 - 16" Brush: BA013000 (30" - Qty. 2)
 - 16" Pad Holder: BA013500 (30" - Qty.2)
 - 20" Brush: BA012800 (38" - Qty. 2)
 - 20" Pad Holder: BA013700 (38" - Qty. 2)

Your Authorized Amano Pioneer Eclipse Distributor: _____

Authorized Amano Pioneer Eclipse Distributor Phone Number: _____

Amano Pioneer Eclipse Phone Number: +1-336-372-8080

Safety Precautions

Anyone operating the machine should read the following carefully and be informed of potentially dangerous operating conditions. Operators should be familiar with the location and use of all safety devices on the machine. Do not use the machine if it is not in proper operating condition, and report any damage or operation faults immediately.

DANGER! Operate this machine in a well-ventilated area. It is the responsibility of the machine operator, machine owner, and the site manager to ensure that the air exchange system where the machine is to be used is in compliance with local building codes and is operating properly. Failure to operate this machine in a well-ventilated area could lead to sickness, injury, or death from carbon monoxide (CO) exposure.

DANGER! This machine emits CO, which is colorless, odorless, non-irritating gas. The first symptoms of CO exposure include headache, drowsiness, dizziness, and nausea. If you should experience any of these symptoms while operating the machine, shut off the machine and go outside to get fresh air. Have the machine tested for CO emissions by a qualified service technician before using it again.

DANGER! Prolonged or high exposure to CO may result in vomiting, confusion, and collapse in addition to loss of consciousness and muscle weakness. If such symptoms occur, call 911 for emergency medical attention. If you have experienced these symptoms, **DO NOT** operate this machine or any other propane machine again until cleared by a physician. Excessive exposure to CO can result in death.

DANGER! Propane is a highly flammable fuel. If you smell propane, shut off the machine immediately and take it outside the building. **DO NOT** use the machine again until a qualified service technician has corrected the propane leak. **DO NOT** use or allow another person to use an ignition source such as a cigarette lighter near the propane machine. **DO NOT** smoke near the propane machine. **DO NOT** vent a propane cylinder inside a building. **DO NOT** store propane cylinders inside a building.

DANGER! This machine has parts, including the pad assemblies, that can cause severe injury if these parts are contacted while they are moving. **DO NOT** allow any part of the body or clothing to come in contact with these parts while they are moving. **DO NOT** try to change attachments while the machine is running. **DO NOT** allow other people to come near the machine while it is in operation. **DO NOT** allow the machine to run unattended. **DO NOT** leave the machine in a place where unauthorized or untrained personnel could use the machine. **DO NOT** run the machine with the pad off center, damaged or missing. **DO NOT** run machine with unsecured guards and shields. **DO NOT** operate the machine if the machine has loose parts.

DANGER! Federal law and California State law prohibits the following acts or the causing thereof: (1) the removal or rendering inoperative by any person other than for purposes of maintenance, repair, or replacement, of any device or element of design incorporated into any new engine for the purpose of emission control prior to its sale or delivery to the ultimate purchaser or while it is in use, or (2) the use of the engine after such device or element of design has been removed or rendered inoperative by any person.

Among those acts presumed to constitute tampering are the acts listed below: **DO NOT** tamper with the original emission related part.

- Throttle body and internal parts
- Spark plugs
- Magneto or electronic ignition system
- Air cleaner elements
- Crankcase
- Cylinder heads
- Breather chamber and internal parts
- Intake pipe and tube
- Regulator
- Fuel lock-off

WARNING! Overfilled or liquid withdraw cylinders can damage the fuel system and create a fire hazard. **DO NOT** overfill the cylinder or use a liquid withdraw cylinder on the machine. If the regulator freezes stop the burnisher and take the cylinder outside. Inspect cylinder, if a vapor withdraw cylinder, use gloves or pliers to open bleeder valve and purge cylinder until only vapor is escaping. If it is a liquid withdraw cylinder, replace with a vapor withdraw cylinder. Both cylinders are shown below.

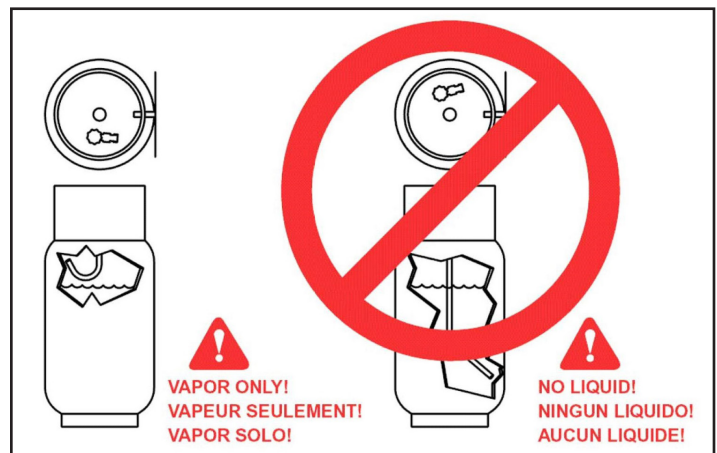

WARNING! Modifications or alterations to this machine can lead to personal injury or damage to the machine. **DO NOT** make unauthorized modifications or alterations to this machine. Amano Pioneer Eclipse assumes no liabilities for injury or damage resulting from an unauthorized modification or alteration to the machine. Any unauthorized modification or alteration to this machine voids all warranties.

WARNING! The muffler and the engine become hot enough while the machine is in operation, and for a long time after the machine is shut off, to cause severe burns. **DO NOT** touch these parts of the machine until they have cooled.

WARNING! Injury can occur to the eyes and body while using the machine. Safety goggles, safety shoes, and safety clothing are recommended while operating the machine.

WARNING! Continuous exposure to high noise levels can cause hearing loss. Hearing protection is recommended while the machine is in operation.

WARNING! Machine vibration may cause tingling or numbness in the fingers or hands. Gloves are recommended to reduce machine vibration. If tingling or numbness persists, shut off the machine. If the vibration is caused by loose parts, adjust or tighten these parts before using the machine again.

WARNING! Do not engage clutch to rotate brushes unless they are in contact with floor. This can damage the brushes and/or the deck.

WARNING! Do not operate machine on a dry floor, as this may result in damage to the brush and/or the deck.

CAUTION! A dirty engine filter can cause overheating. Check and replace following recommended maintenance schedule.

CAUTION! Overheating can be caused by insufficient or low oil. Check oil before each use, and fill or change as needed.

CAUTION! Never over-fill engine with oil. Over-filling could cause irreparable damage to the engine.

CAUTION! Overheating can be caused by dirty oil. Check oil before each use and change regularly following recommended maintenance schedule.

CAUTION! Do not engage starter for more than 5 seconds. Allow a 10 second cool-down period for second failed start-up attempt.

CAUTION! Perform all recommended scheduled maintenance. Regular maintenance of your propane powered floor machine is necessary to keep it in safe working condition.

CAUTION! DO NOT operate machine unless trained and authorized. **DO NOT** operate machine unless you have read and understand the operation manual. **DO NOT** operate machine in flammable or explosive areas.

CAUTION! Before starting machine ensure all safety devices are in place and functioning properly. Before starting machine check for proper operation.

CAUTION! When using machine, go slowly on inclines or slippery surfaces. Use care when operating machine in reverse.

CAUTION! When servicing machine, stay clear of moving parts. **DO NOT** wear loose clothing when working on machine. Block machine wheels before raising or jacking up machine. Use hoist stands that will support the weight of the machine. Wear eye and ear protection when using pressurized air or water. Disconnect battery connections before servicing machine. Use only replacement parts supplied by Amano Pioneer Eclipse or a Amano Pioneer Eclipse Authorized Distributor or Service Center.

CAUTION! When loading or unloading machine onto or off a truck or trailer, turn machine OFF. Only use a truck or trailer that will support the weight of the machine to transport. **DO NOT** push the machine onto or off a truck or trailer unless the load height is 15 in (380mm) or less from the ground. Block machine wheels when transporting. Tie the machine down securely to truck or trailer when transporting.

CAUTION! Do not allow the machine to operate without moving, it may damage the floor covering.

This machine is manufactured for commercial use only.

This machine is designed and manufactured for commercial floor stripping only. Amano Pioneer Eclipse does not recommend use of this machine in any environment other than an indoor environment. This machine is designed to strip most modern types of flooring including composition tile, stone, marble, terrazzo, concrete, and resilient floor covering. Even though NFPA 11.13.2.3 says...“the use of floor maintenance machines in buildings frequented by the public, including the times when such buildings are occupied by the public, shall require the approval of the authority having jurisdiction.” Amano Pioneer Eclipse suggests usage when occupancy of a given work area is minimal.

These machines should not be used

- In nursing homes, hospitals, day-care centers, etc. that are occupied.
- By unqualified or untrained personnel.
- Unless properly maintained and adjusted.
- On areas with obstructions such as thresholds, floor outlet boxes, etc.
- In areas where loose debris or other objects are present.
- In rooms and areas without proper ventilation

Operator Responsibility

The operator is responsible for performing the recommended daily maintenance and checkups of the machine to keep it in good working condition. The operator must inform the service mechanic or supervisor when recommended maintenance procedures are required as described in the “*MAINTENANCE*” section of this manual.

- Read this manual carefully before operating this machine.
- FOR SAFETY: **DO NOT** operate machine before reading and understanding the operation manual.
- Check the machine for shipping damage.

Keep your machine regularly maintained by following the maintenance information in this manual. Order parts and supplies only from an Authorized Amano Pioneer Eclipse Distributor. Use the parts illustration section of your manual when ordering parts.

During and after operation, perform the recommended daily and hourly procedures outlined in the Maintenance Chart.

Refueling and Storage of Fuel Cylinders

This machine uses a 20lb (9.1kg) capacity aluminum or steel cylinder, which meets the DOT 4E240 standards. These cylinders are also listed by UL. In addition, the steel cylinder meets European TPED specifications and is CE compliant. Filling should be done **ONLY** by a qualified propane dealer. **FILL THROUGH THE SERVICE VALVE ONLY.** A properly filled cylinder should not exceed 80% of the rated capacity.

DO NOT attempt cylinder repair. Return the cylinder to your propane dealer if repair is necessary. Please note that DOT regulations prohibit shipping of cylinders after the cylinder has been filled with propane. When not in use, cylinders should always be stored outside in an upright position in a secure, tamper-proof, steel mesh storage cabinet. The cabinet may be located next to the building, but with at least five feet (1.5 m) of space between the cabinet and the nearest building opening (door or window).

The cylinder to be used on this machine is a vapor withdraw cylinder. **A liquid withdraw cylinder is not to be used with this machine.** The use of a liquid withdraw cylinder on a vapor withdraw system could freeze the regulator and create a fire hazard. The National Fire Protection Association (NFPA) Standard for Storage and Handling of LP Gas is the appropriate authority for safe propane use. A copy of this publication is available through the National Fire Protection Association (1-800-344-3555) or www.NFPA.org.

Canadian Safety Requirements

1. A sign indicating "NO SMOKING" shall be permanently displayed at the storage area. The sign shall be in accordance with the sign required in Clause 10.12.3 of CAN/CGA-B149.2-M91, Propane Installation Code.
2. When the cylinder is attached to the floor maintenance machine for use, the operator shall not leave the unit unattended except for short periods of time such as rest stops, washroom, or meal stops.
3. The requirements of 1.10.1 (e) and (g) do not apply in industrial buildings.
4. A floor maintenance machine shall only be used in buildings:
 - a. Provided with continuous mechanical ventilation that removes products of combustion to the outdoors of not less than 300 CFM for each 10,000 BTU-hr or fraction thereof.
 - b. Provided with natural ventilation of not less than 300 CFM for each 10,000 BTU-hr input or fraction thereof, based on a maximum of one-quarter-air exchange per hour for the net building volume.
5. The owner of a floor maintenance machine shall ensure that the operator has participated in a course authorized by the manufacturer of the unit on the safe handling of propane and the safe operation of the machine.
6. The owner of a floor maintenance machine shall ensure that the unit is maintained in accordance with the manufacturer's recommended maintenance procedures in a safe operating condition and the owner shall maintain a record of the maintenance for a period of two years.
7. Before transporting a floor maintenance machine, the cylinder shall be securely fastened with the system valve closed, and the cylinder shall be located in a well-ventilated space.

Exigences de sécurité pour le Canada

1. Un panneau indiquant " INTERDICTION DE FUMER " doit être affiché en permanence dans la zone de stockage. Il doit être conforme au panneau exigé par la Clause 10.12.3 du CAN/CGA-B149.2-M91, Code installation propane.
2. Lorsque le cylindre est fixé à la machine d'entretien des sols pour son utilisation, l'opérateur ne doit pas laisser l'unité sans surveillance, sauf pour de courtes périodes, notamment pour faire une pause, aller aux toilettes ou au moment des repas.
3. Les conditions du 1.10.1 (e) et (g) ne s'appliquent pas aux bâtiments industriels.
4. Une machine d'entretien des sols ne doit être utilisée que dans les bâtiments suivants :
 - a. Équipés d'un système de ventilation mécanique ininterrompu, capable d'évacuer les produits de combustion vers l'extérieur, non inférieur à 300 CFM pour chaque 10 000 BTU/h ou une fraction de ce dernier.
 - b. Équipés d'un système de ventilation naturel non inférieur à 300 CFM pour chaque 10 000 BTU/h ou une fraction de ce dernier, basé sur un maximum d'un quart d'air échangé par heure pour le volume net du bâtiment.
5. Le propriétaire d'une machine d'entretien des sols doit s'assurer que l'opérateur a participé à une formation habilitée par le fabricant de l'unité, relative à la manipulation sûre du propane et de la machine.
6. Le propriétaire d'une machine d'entretien des sols doit s'assurer que l'unité bénéficie d'un entretien conforme aux procédures de maintenance recommandées par le fabricant dans des conditions d'utilisation sûres. De plus, il doit tenir un registre de la maintenance sur une période de deux ans.
7. Avant de transporter une machine d'entretien des sols, le cylindre doit être fixé de manière sûre avec le système de soupapes fermé. De plus, il doit se trouver dans un espace bien ventilé.

Test for Operator-Ear Sound Pressure Level

Amano Pioneer Eclipse measures and rates the operator-ear sound pressure level for hand-guided floor treatment and floor cleaning machines for industrial use. All tests are performed in accordance with European Machinery Directive (2006/42/EC).

- Outdoor test area consists of a flat open space free from effects of signboards, buildings or hillsides for at least 15 m (50 ft) from the center of the test surface. Indoor tests are conducted in a semi-anechoic or sound deadening room.
- The test surface is a single sheet of floor covering at least 1 m (3.3 ft) wider and longer than the equipment being tested. In order to not affect the sound reading, the observer taking readings is at least 2 m (6.6 ft.) from the equipment being tested, or standing directly behind the operator.
- All machines are tested while stationary and centered on the test surface. With the traction drive in neutral (where applicable) the test is conducted with the machine at maximum engine or motor speed as specified by the manufacturer.
- The operator is located in the normal operating position with the microphone or meter supported independent of the machine, 1,68 m (66 in) above the test surface, 25 cm (10 in) to the right and left centerline of the operators position, and 20 cm (8 in) to the rearmost point of the handle, with the handle in the most forward position.
- The sound level meter is observed for a minimum of 5 seconds or until a stabilized reading is obtained. The maximum repeatable sound level observed during the test at each microphone position is recorded and documented.

Test for Hand-Arm Vibration at the Grip Surface of Hand-Guided Machinery

Amano Pioneer Eclipse measures and rates the vibration at the machine-hand contact surface of hand-guided machines that are provided with handles in accordance with European Machinery Directive (2006/42/EC).

- The test area consists of a flat open floor area that allows the machine to be operated normally.
- The transducer is mounted firmly at a point halfway along the length of the handle where the handle would normally be held.
- Machines are tested while stationary, with all mechanisms necessary for the equipment to perform its intended functions engaged and the traction drive in neutral (if applicable). The machine will be tested at maximum engine or motor speed as specified by the manufacturer of the subject machine.
- The measurements are recorded from the dominant axis.

Machine Preparation

Unpacking the Machine

The machine is shipped boxed on a wooden pallet. To unpack machine:

1. Cut and remove bands holding the box to the pallet.
2. Remove staples attaching the box to the platform at the bottom edge of the box.
3. With two people, one at either end of the box, lift box straight up and off machine.
4. Cut and remove bands securing the machine to the pallet.
5. Remove all bracing.
6. Loosen the handle pivot knobs on both sides of the bulkhead and pull up on the handle. .

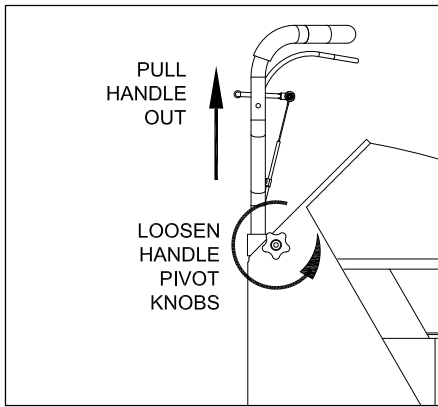

7. Rotate handle downward to the operating position.

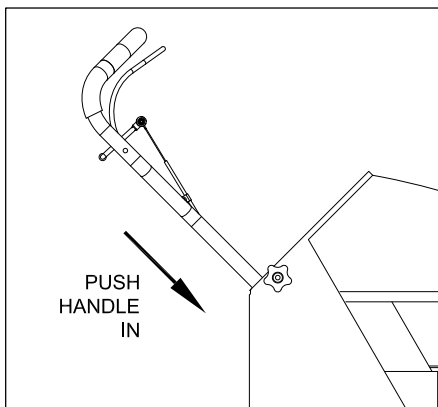
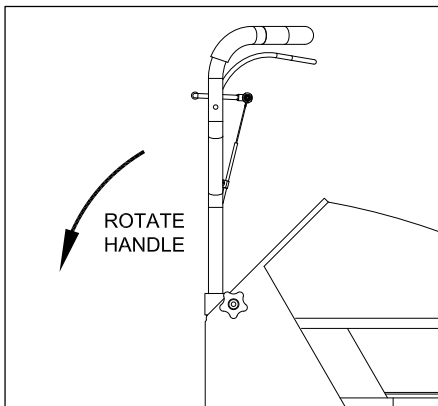

8. Push the handle inward until the handle stops.

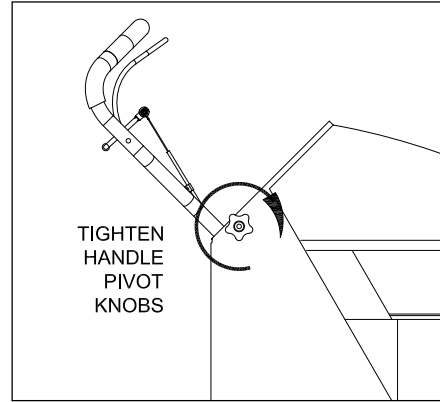

9. Tighten the handle pivot knobs on both sides of the bulkhead.
 10. Check machine fluid levels (engine oil). See *Maintenance* section.
- NOTE: If machine was shipped by airfreight, add engine oil.**
11. Using the transport cart (see Transport Cart section), back the machine off of the pallet.

Filling the LP Cylinder

This machine uses the 20 lb (9.1 kg) capacity cylinder, which meets the D.O.T. 4E240 standards. These cylinders are also listed by UL. In addition, the steel cylinder meets European TPED specifications and is CE compliant. Filling should be done **ONLY** by a qualified propane dealer. A properly filled cylinder should not exceed 80% of the rated capacity. Do not overfill the cylinder or use a liquid withdraw cylinder on the machine. The use of a liquid withdraw cylinder on a vapor withdraw system could freeze the regulator and create a fire hazard.

Installing the LP Cylinder

Place the cylinder on the cylinder platform at the back of the machine. Connect the fuel hose coupling to the service valve by turning to the right (clockwise). **HAND TIGHTEN ONLY!** Make sure coupling is not cross threaded and check for leakage by noting any propane odors immediately after cylinder is connected. Finally, secure the tank to the machine using the adjustable strap. Remove slack by pulling on the loose end and securing with the Velcro.

TO REMOVE THE LP CYLINDER, reverse the above procedure. Always connect or change cylinders in a well-ventilated area.

Machine Components

Controls and Instruments



Bail Throttle

Handle Pivot Knob

SafeStop Light (optional)



Hour Meter / Tachometer

Engine Ignition Switch

SafeSense Light Display

Engine Ignition Switch

This machine features a key switch ignition.

START: Turn the key all the way clockwise to engage the engine starter motor. Once the engine starts release the key.

NOTE: Always start this machine with the bail throttle in the idle or "SLOW" position.

RUN: This is the position of the key while the engine is running.

OFF: Turn the key to the "OFF" position to stop the engine from running.

NOTE: For safety, always close the propane cylinder valve to stop the engine and then turn the key switch to the "OFF" position.



Hour Meter / Tachometer

The hour meter / tachometer records the number of hours the machine has been powered "ON". The hour meter reading is used to mark recommended maintenance intervals. It also displays the engine speed. This meter displays hours when the machine is turned "OFF" and engine speed when the engine is running.



Bail Throttle



Do not try to start the machine with the bail throttle in the operating position.

After the engine has started and the brushes on the floor, pull the bail throttle to the operating position. The clutch will engage automatically and the engine will throttle to the correct speed.

CAUTION! DO NOT pull the bail throttle unless the brushes are on the floor.

Release the bail and the clutch will automatically disengage. The engine speed will return to idle.

Fuse

The machine's electrical circuit is protected by a fuse, which stops the flow of current in the event of a circuit overload. Once a fuse blows, it must be replaced. If the overload that caused the fuse to fail is still present, the new fuse will fail and the problem must be corrected. **DO NOT** bypass any fuse. The ignition fuse is located on the side of the starter switch panel.

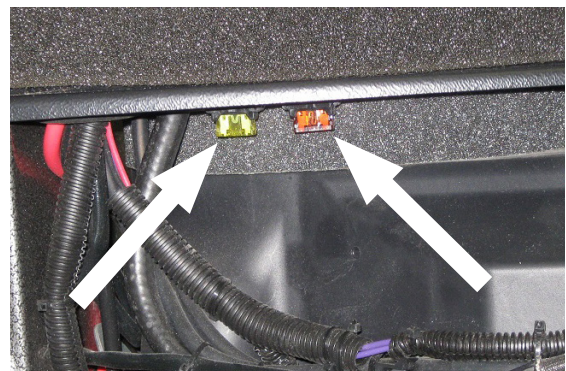

SafeSense Emissions Monitoring System

SafeSense is an emissions monitoring device that monitors the exhaust emissions and will shut the engine down if the emissions levels are too low or too high.



NOTE: After engine starts, the **YELLOW** alert light will flash for a 3 minute warm-up cycle of the SafeSense system. (The machine may be operated during this warm-up period.) After the warm-up cycle, the alert light will go out. None of the SafeSense lights will be illuminated as long as the machine is running safely.

OIL: Light comes on when there is low oil pressure. If the engine loses oil pressure, the engine shuts down until the condition is corrected. The light comes on each time the engine is stopped.

TILT/IDLE: Light comes on when the machine is tilted to the pad change position and the engine shuts down. If the machine is allowed to idle for more than 4 minutes, the light flashes for 1 minute then the engine shuts down.

RED SafeSense SERVICE: If carbon monoxide levels exceed a pre-set level, the light will flash. The machine will shut down after the light flashes continuously for one minute. If the machine does not operate normally after the engine air filter is checked and cleaned, it must be serviced by a qualified technician.

OXYGEN SENSOR: If light comes on during normal operation, check the oxygen sensor wire for a snug fit into the harness and for a snug fit of the harness into the SafeSense board. If the light still remains on, the machine must be serviced by a qualified technician.

TURN GAS OFF: Light comes on to remind the operator to turn off the gas after the engine shuts down.

BATTERY: Light comes on when the battery voltage is low indicating the need to service charging system.

YELLOW SafeSense ALERT: If light comes on during normal operation, check and clean the engine air filter. Check the carburetor air filter for holes, tears, or punctures and replace if damaged. If the light still remains on, the machine must be serviced by a qualified technician.

NOTE: Any light that is on when the engine stops will remain illuminated for 20 seconds to indicate the reason for machine shut down.

The oxygen sensor must reach operating temperature before it will start to send signals to the SafeSense module. This warm up period is approximately 3 minutes. After the initial 3 minutes, the module will start evaluating the signal from the oxygen sensor and if the module receives an abnormal reading for a period of 1 minute, the unit will shut down. If the machine is also allowed to idle for more than 4 minutes, an indicator light will flash for 1 minute and then the engine will shut down. If this happens, turn the key to the "off" position several seconds to clear the SafeSense module and restart the engine. Once the engine has started, advance the bail throttle to operating position and start the operation. With the engine at full throttle, under load, the signal from the oxygen sensor should be within the normal operating ranges for safe operation. If the engine's air intake filter needs to be serviced, or an over-filled cylinder has been installed by mistake, or there is a problem with the fuel system that causes the oxygen sensor's signal to be out of range, SafeSense will shut the unit down after 1 minute. The unit can be re-started after clearing the module by turning off the key switch. If corrections have not been made to the unit, SafeSense will continue to shut the unit down until the problem is corrected.

Engines tend to go to a lean burn if allowed to idle for even short periods. Even at high idle speeds most engines will continue to lean downward. It is always best to shut the engine off when it is not being used to do work. Remember, the engine is always creating emissions as long as it is running.

The best manner to operate a unit equipped with SafeSense is as follows.

1. With the bail throttle in the idle position, turn the key switch to the start position, once the engine starts, advance the bail throttle to the operating position.
2. When ready to stop operation, release the bail throttle. If the unit will not be used within forty-five seconds, turn the key switch to the off position. If the unit will not be returned to service within a few minutes it is best to turn the gas valve on the tank off first and let the engine consume all fuel that is in lines. Once the engine dies, turn the key switch to off position.
3. When ready to restart, open the gas valve on the tank, and turn key switch to the start position. Once the engine has started, move bail throttle to the operating position and return to operation.

SAFR™ technology monitors the pressure between the air filter and the carburetor. As the air filter becomes dirty, this pressure decreases. With **SAFR™** technology, this change in pressure results in a reduction in fuel delivered to the engine. The net result is a Steady Air Fuel Ratio regardless of the air filter condition.

Rok-Bak

1. Close the valve on the propane cylinder, allow the engine to stop and turn the machine "OFF".
2. Remove the propane cylinder.
3. Loosen the handle pivot knobs on each side of the bulkhead.
4. Pull the handle out until it stops.
5. Rotate the handle towards the front of the machine until it is vertical.
6. Push downward on the handle until it stops.

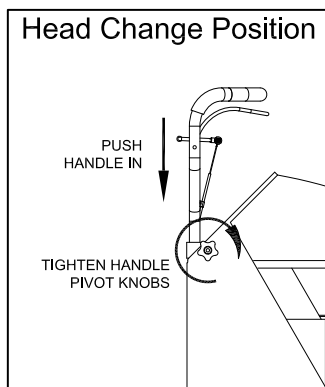
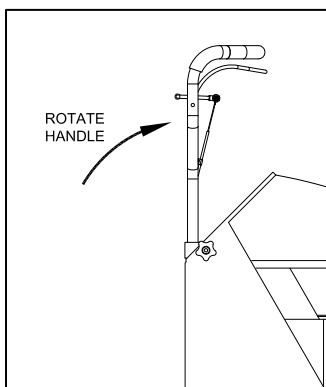
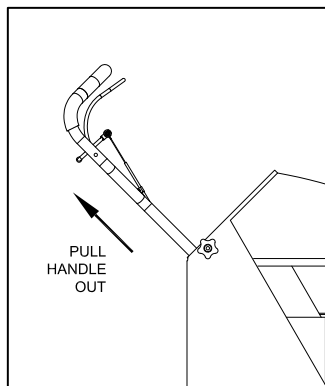
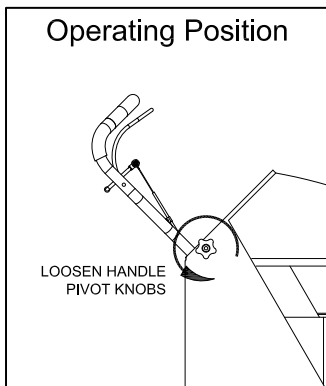

7. Tighten the handle pivot knobs so the handle cannot move or slide.

NOTE: The floor stripping machine is heavy and may require two people to lift and lower the machine safely.

8. Raise the splash skirt around the deck exposing the deck frame. Use the transport cart pivot arm and/or the notch in the front of the deck to lift the machine to a full upright position.

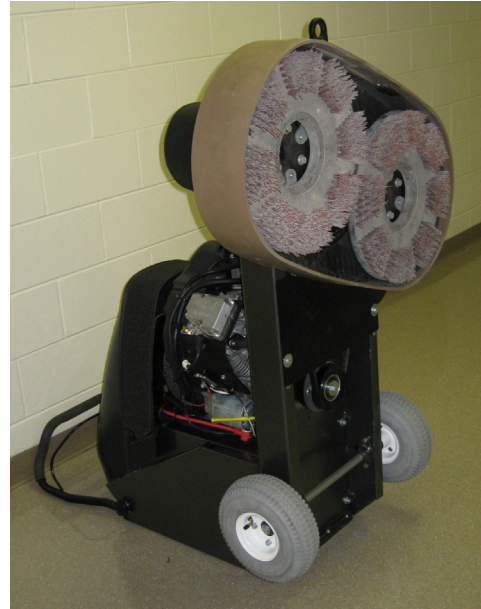

CAUTION! Before lowering the machine back to the floor, be sure that brushes are attached to the machine to prevent someone from damaging their hands and/or fingers. This also will prevent any damage to the head drive assembly.

9. When lowering the machine down, **DO NOT** drop the machine. Slowly lower the machine to the floor until the wheels and brushes are on the ground.
10. Loosen the handle pivot knobs and place the handle in the operating position. Adjust the handle to the desired operating position and tighten the handle pivot knobs.

SafeStop (optional)

SafeStop is a system that monitors the fuel system and stops engine operation if either an overfilled cylinder or liquid draw cylinder is used. If SafeStop is activated, the red LED will illuminate and the engine will stop operating. If this occurs, remove the cylinder from the machine, take the cylinder outside, and verify it is a properly filled vapor draw cylinder. Note: This system is not a substitute for properly inspecting propane cylinders prior to bringing inside a facility. Overfilled or liquid draw cylinders can damage the fuel system and create a fire hazard. Refer to the Safety Precautions section in this manual.

Pad / Brush Change

1. Place the machine in the Rok-Bak position. (see Rok-Bak section)



2. Facing the brushes from the front of the machine, turn the brush on the right counter-clockwise with a quick motion and pull the brush towards you. Turn the brush on the left clockwise with a quick motion and pull the brush towards you.

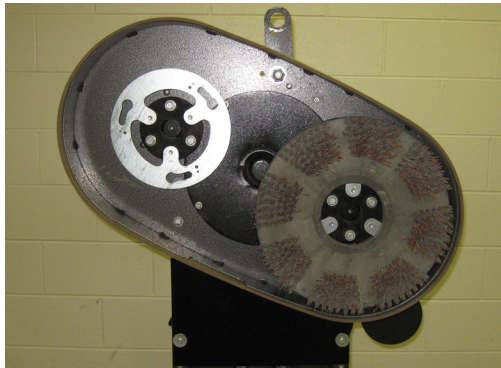

CAUTION! Carefully inspect the brush/pad holder for cracks or damage. Replace if necessary.

WARNING! A damaged brush/pad holder rotating at high speeds may be an extreme hazard if it should come apart.

3. While facing the machine from the front, place the brush on the right into the slots and turn clockwise with a quick motion. Make sure the brush snaps into place. Place the brush on the left in the slots and turn counter-clockwise with a quick motion. Make sure the brush snaps into place.
4. Verify that all three lugs of both brushes are correctly installed. If all three lugs are not properly installed, it is possible that the brush could come loose from the assembly. This may also cause damage to the machine and/or floor.
5. The machine can now be lowered to the floor

DO NOT store the machine with the brushes in contact with the floor. The brushes could flatten during storage. Always store the machine using the transport cart to hold the brushes off of the floor.

Handle Adjustment

1. The height of the handle can be adjusted by raising or lowering the handle.
2. Loosen the handle pivot knobs on the sides of the bulkhead, turning the right side counter-clockwise and the left side clockwise.

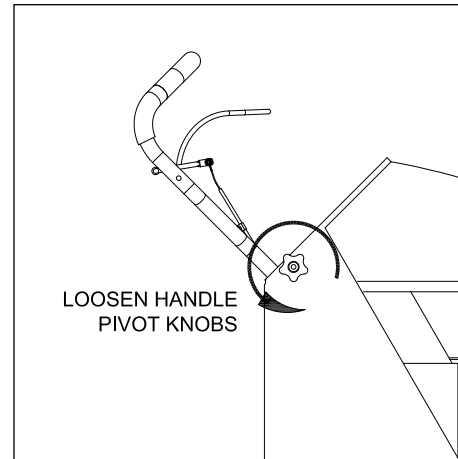

3. Move the handle in and out to the desired height

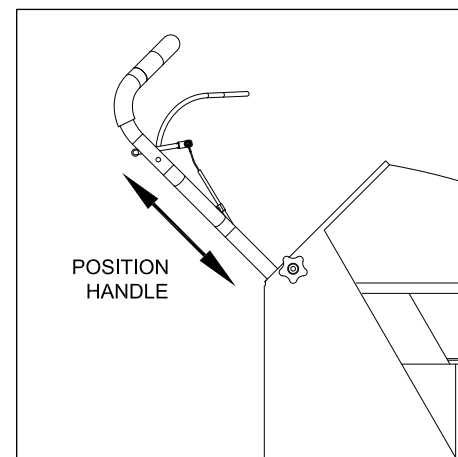

4. Tighten the handle pivotknobs.

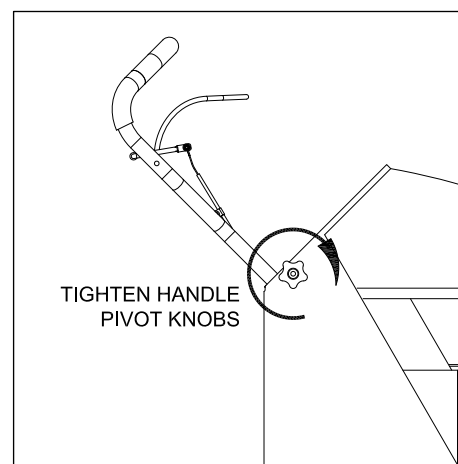

Transport Cart

1. Locate the transport arm located on the front of the deck and remove the pull pin.



2. Rotate the arm to an outward position. Reinsert the pull pin to lock the arm in the outward position.



3. Place the hook of the transport cart inside the hole of the transport arm. In one smooth motion, pull the handle up and over rotating the transport cart on the two main wheels.



4. With the brushes off the floor the machine is ready to move.



5. To remove the transport cart, place the cart and the machine in a straight line.
6. Use the handle of the transport cart and pull the handle up and over towards the machine. The cart will rotate on the two main wheels and disconnect from the transport arm.

How the Machine Works

This machine is a propane stripper that has a gearbox assembly that is belt driven directly from the engine crank shaft.

Pre-Operation Checklist

- Check the engine oil level. Add oil if needed. Refer to *Maintenance*.
- Inspect the engine dust filter and clean off any debris or dust buildup. Refer to *Maintenance*.
- Inspect the burnishing pad and replace, if necessary. Refer to *Maintenance*.
- Inspect the brushes / pad holders for cracks or damage! Replace if necessary. Refer to *Maintenance*.

WARNING! A DAMAGED BRUSH / PAD HOLDER ROTATING AT HIGH SPEEDS MAY BE AN EXTREME HAZARD IF IT SHOULD DISINTEGRATE.

- Inspect air filter. Clean or replace if necessary. A dirty air filter could lead to elevated levels of carbon monoxide. Refer to *Maintenance*.
- Inspect the drive belt. Replace if necessary. Refer to *Maintenance*.
- Check the machine for leaks or loose fasteners.

LP Fuel Cylinder

This machine uses the 20 lb (9.1 kg) capacity cylinder, which meets the D.O.T. 4E240 standards. These cylinders are also listed by UL. In addition, the steel cylinder meets European TPED specifications and is CE compliant. Filling should be done ONLY by a qualified propane dealer. A properly filled cylinder should not exceed 80% of the rated capacity. Do not overfill the cylinder or use a liquid withdraw cylinder on the machine. The use of a liquid withdraw cylinder on a vapor withdraw system could freeze the regulator and create a fire hazard.

Only Use a Vapor Cylinder!

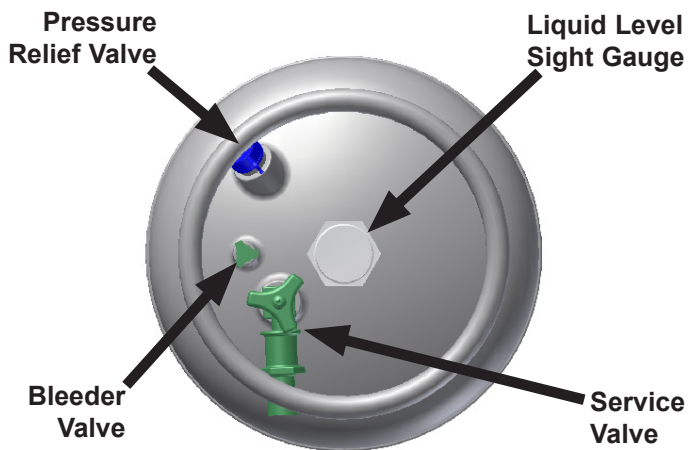
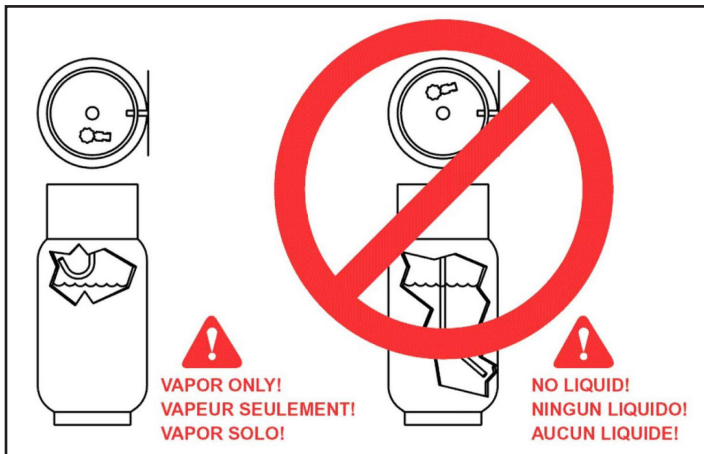

Installing the LP Cylinder

1. Before bringing a propane cylinder indoors, always check it for over-filling.

CAUTION! Always connect or change cylinders in a well ventilated area.

2. Place the tank on the machine and secure with the retaining strap. Remove slack by pulling on the loose end of the strap and secure back to strap.



3. Connect the fuel hose coupling to the service valve by turning clockwise ("HAND TIGHTEN ONLY"). Make sure coupling is not cross threaded and check for leakage by noting any propane odors immediately after cylinder is connected.



NOTE: It is sometimes easier to install if the connection to the service valve is made before strapping the cylinder in place.

CAUTION! Always open service valve slowly to allow pressure to equalize in hoses. Opening quickly may cause the flow check valve to engage, limiting fuel flow.

4. To remove the cylinder, reverse procedure.

Starting the Machine

1. Check oil and fuel levels.
2. Check and clean engine dust filter.

CAUTION! *Never run continuously for more than one hour without cleaning or changing engine dust filter.*

3. Check carburetor air filter. Change if necessary. (See "Scheduled Maintenance")
4. Turn propane service valve counterclockwise to open.

CAUTION! *Always open service valve slowly to allow pressure to equalize in hoses. Opening quickly may cause the flow check valve to engage, limiting fuel flow.*

5. With the bail throttle in the idle position, engage the starter by turning the key switch to the starting position for approximately 5 seconds. If the engine does not start, release the key switch for 10 seconds, then try to start again in another 5 seconds.
6. After the engine has started, allow the engine to warm up for approximately 30 seconds.

WARNING! *Catalytic mufflers require a few minutes to warm up before effectively removing harmful emissions. Make sure of proper ventilation during this warm-up period!*

Idling and Stopping the Machine

DANGER! Allowing the engine to idle excessively will increase carbon monoxide emissions!

To stop the engine, close the service valve on the fuel cylinder by turning it clockwise (the engine will stop when the fuel in the lines is used up). Once the engine stops, turn the ignition switch off.

Stripping

1. After engine has started, allow approximately 30 seconds for the engine to warm up.
2. If the transport cart is in place, remove it allowing the brushes to contact the floor.
3. Pull the bail throttle to operating position.

CAUTION! DO NOT *engage clutch with the brushes not on the floor.*

CAUTION! DO NOT *run the burnisher without moving the machine. If the machine is allowed to run in one spot, damage to the floor may occur.*

4. To stop stripping, release the bail throttle.

CAUTION! DO NOT *add weight to the deck.*

CAUTION! DO NOT *lift up on the handle to add pressure while stripping.*

NOTE: *To not comply with any of the CAUTION! statements could cause the engine to overheat and/or damage the brush / pad holder or drive components.*

5. When done stripping, push the machine to the desired location. Turn off the LP cylinder service valve. When the fuel is depleted and the engine stops, turn the key switch OFF.
6. Remove the LP cylinder and store properly. Refer to *Refueling and Storage of Fuel Cylinders.*

Machine Troubleshooting

Problem	Possible Cause	Solution	
Engine is hard to start	Propane cylinder is not properly connected.	Check connection and open service valve slowly.	
	Battery is weak.	Charge battery or replace.	
	Oil level is to low.	Check the oil level and add if needed.	
	Insufficient vacuum.		Place the engine throttle in the idle "slow" position.
			Check the regulator vacuum hose for breaks, pinched hose, or a bad connection.
	Coil air gap out of adjustment.	Adjust coil air gap (Check FS481V Service Manual). Contact an APEC Certified Technician.	
	Spark plug or head bolts loose.	Retorque (Check FS481V Service Manual). Contact an APEC Certified Technician.	
Head gasket blown or valves need adjusting	Replace head gasket, adjust valves and replace if necessary (Check FS481V Service Manual). Contact an APEC Certified Technician.		
Engine will not start	Propane cylinder is empty.	Install properly filled cylinder.	
	Oil level is to low.	Check the oil level and add if needed.	
	Machine is in the pad change position.	Lower the machine to operating position.	
	Main fuse is blown.	Inspect fuse and if blown replace	
	Insufficient vacuum.		Place the engine throttle in the idle "slow" position.
			Check the regulator vacuum hose for breaks, pinched hose, or a bad connection.
	Head gasket blown or valves need adjusting.	Replace head gasket, adjust valves and replace if necessary (Check FS481V Service Manual). Contact an APEC Certified Technician.	
	Wires broken or disconnected.	Reconnect or replace wires. Contact an APEC Certified Technician.	
	Coil(s) defective.	Replace coil(s) (Check FS481V Service Manual). Contact an APEC Certified Technician.	
	Spark plug gap is incorrect.	Adjust gap to 0.025" (.64mm)	
	Spark plug defective.	Replace spark plug.	
Econsense shut the machine down		If the light is on, turn the key switch off and wait 30 seconds. Try again.	
		Bad module. Contact an APEC Certified Technician.	
Engine lacks power	Dirty air filter(s).	Clean or replace the engine dust filter.	
		Clean or replace the primary filter (paper element).	
		Clean or repalce the secondary filter (foam element).	
	Governor out of adjustment or malfunctioning.	Adjust governor and replace if necessary (Check FS481V Service Manual). Contact an APEC Certified Technician.	
	Head gasket leaking.	Replace head gasket (Check FS481V Service Manual). Contact an APEC Certified Technician.	
	No compression.	Worn piston ring(s) and/or cylinder head(s) require replacement (Check FS481V Service Manual). Contact an APEC Certified Technician.	
	Fuel mixture is to lean.	Check and adjust fuel mixture if necessary. Contact an APEC Certified Technician.	
Valves need adjusting or replacing.	Adjust valves (Check FS481V Service Manual). Contact an APEC Certified Technician.		
Smell or bumed rubber	Belt out of adjustment.	Check the automatic tensioner	
Machine vibrates	Loose fasteners.	Check the engine, tensioner, spindle, and pad holder fasteners. Tighten any fasteners that may be loose.	
	Pad is not centered on the pad holder.	Remove pad and re-center on padholder. Replace the pad with a new pad if necessary.	
	Padholder is out of balance.	Remove pad holder from the macine and clean both sides. Check for cracks or tears. Replace if necessary.	
Machine is burnishing too aggressively	Wheels are adjusted to far back.	Move both wheels forward in the wheel bracket.	
	Improper pads.	Only use recommended burnishing pads.	
Machine pulls to one side	Bent wheel bracket.	Replace wheel bracket.	
	Wheel is worn or a bad bearing.	Replace wheel.	
	Wheels are adjusted to far back.	Move both wheels forward in the wheel bracket.	
Engine stops running	Propane cylinder is empty.	Install properly filled cylinder.	
	Operator presence switch not engaged.	Engage one of the switch levers while running the machine. Machine will only run for 30 seconds without one of the switch levers engaged.	
	Engine oil level is too low.	Check the oil level and add if needed.	
	Dirty air filter(s).	Clean both filters or replace if necessary.	
	EcoSense shut the machine down		Clean all filteres or replace if necessary.
			Check for any loose wiring or fuel line connctions.
Safe-Stop shut the machine down.		Install properly filled cylinder.	
		Replace liuid cylinder with vapor cylinder.	
Dust collection not working properly	Dust collection bag is not collecting dust.	Empty the dust bag.	
		Check the dust scoop and/or the dust tube to see if there is an obstruction.	
	Skirt is not dealing to the floor.	Skirt is bent or damaged. Replace if necessary.	
		Adjust the skirt to fit tightly against the seal, but still be able to move freely. Check wear edge on bottom of the skirt and replace if necessary.	

Maintenance

Scheduled Maintenance

Operation	Interval			
	Daily	First 100 Hrs.	Every 250 Hrs	Every 500 Hrs.
Check & add engine oil	●			
Check for loose or lost fasteners	●			
Check for oil leakage	●			
Inspect fuel hose and connections	●			
Clean Engine dust filter	●			
Inspect pad holder	●			
Change engine oil filter		●	●	
Change Sentinel Propane Engine Oil		●	●	
Check & clean air cleaner paper element	●			
Check & clean air cleaner foam element	●			
Inspect battery and battery connections			●	
Replace air cleaner paper element			●	
Replace air cleaner foam element			●	
Inspect, clean, & re-gap spark plugs, Replace if necessary			●	
Check & adjust valve clearance.* Retorque heads.*			●	
Clean & lap valve seating surface.*			●	
Check engine emissions				●
Clean cooling fins			●	
Inspect drive belt			●	
Inspect burnishing head assembly	●			
Replace drive belt	As Required			
* Check FS481V Service Manual. Contact Amano Pioneer Eclipse Certified Technician.				

Oil Level Inspection

1. Push machine to level surface.
2. Turn off LP cylinder and remove it.
3. Clean area around the oil gauge before removing it.
4. Remove the oil gauge and wipe it with a clean cloth.
5. The machine should be in an upright level position. If necessary, place a block under the back of the machine or apply weight to the front of the deck to maintain an upright, level position.



6. Insert the oil gauge into the tube, but do not tighten the oil gauge.
7. Check the oil level. It should be between the "FULL" and "ADD" marks on the oil gauge.

NOTE: If the oil level is near or below the "ADD" mark, remove the oil gauge and add enough engine oil to bring oil level to the "FULL" mark. (Use only SH or SJ SAE30 Oil)

NOTE: If the oil level is too high, remove the excess oil by loosening the oil drain valve.

CAUTION! Do not fill above the "FULL" mark. Excess oil will cause a smoking condition and may cause the engine to overheat.

Oil Change

1. Use only Sentinel Synthetic Propane Engine Oil. Sentinel is specially formulated for small, hot-temperature engines and provides a longer 250 hour service interval. If conventional SH or SJ SAE 30 oil is used instead of Sentinel, scheduled maintenance MUST revert to every 100 hours to maintain engine warranty.
2. Change the oil after the first 100 hours of operation and every 250 hours or 90 days, whichever occurs first.
2. Start and warm the engine so the oil will drain easily and completely. Push machine to a level surface. Stop the engine.
3. Turn off LP cylinder and remove it.



4. Locate the drain hose inside the bulkhead compartment. Lower the drain hose from the clamp and remove the cap on the end of oil drain hose
5. Place a suitable container under the end of the oil drain hose.

WARNING! Be careful with hot oil being drained. It may be hot enough to cause severe burns.



6. Slowly turn the valve counter-clockwise, until the oil starts to drain.

NOTE: In order for the oil to drain, it may be necessary to loosen the oil fill cap.

8. When the oil has finished draining, close the drain valve and place cap back on the end of the valve.
9. Remove oil cap and add clean SH or SJ SAE 30 oil. Use 1.6 U.S. qt. (1.5 L) when the filter is not changed and 1.8 U.S. qt. (1.7 L) when filter is changed.
10. Screw in oil gauge. Reconnect the LP cylinder to the fuel hose.
11. Run the engine at low idle for 2 minutes. Check for leaks around the engine.
12. Stop the engine. Check the oil level (see *Oil Level Inspection* section).

Oil Filter Replacement

1. Place a suitable container underneath the oil filter.
2. Using a strap wrench or oil filter wrench, remove the oil filter. Turn the filter counter-clockwise to remove it.
3. Apply a thin coat of new oil or grease to the oil filter seal (-B-).
4. Install the new filter (-A-) (**Part #: KA490657007**) by turning it clockwise.

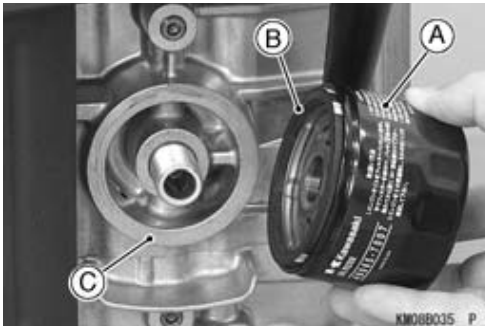

5. Turn the filter until the seal contacts the mounting surface (-C-) of the engine. Then, turn the filter "BY HAND" 3/4 turn more.
6. Reconnect the LP cylinder to the fuel hose.
7. Run the engine at low idle for 2 minutes. Check for leaks around the engine.

Spark Plug Inspection and Replacement

1. Turn off LP cylinder and remove it.
2. Pull spark plug cap off of spark plug.
3. Remove spark plug by turning counter-clockwise and inspect it.

NOTE: If the plug is oily or has carbon build up on it, clean the plug using a high flash-point solvent and a wire brush or other suitable tool.

NOTE: If the spark plug electrodes are corroded or damaged, or if the insulator is cracked, replace the plug. Use Only **Part #: KA920702112**. **DO NOT use any other spark plug!**

4. Measure the gap with a wire-type thickness gauge. The correct gap is .025 in (.635 mm). If the gap is incorrect, carefully bend the side electrode with a suitable tool to obtain the correct gap.

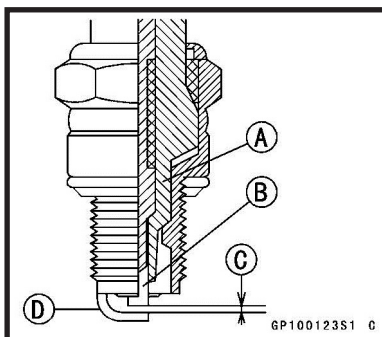

- A: Insulator
- B: Center Electrode
- C: Plug Gap
- D: Side Electrode

Hood Removal

The hood must be removed to gain access to the LP fuel regulator, starter solenoid, starting battery, and electrical components. Remove the two knobs, one of each side of the hood. With the knobs removed pull toward the front of the machine and lift the hood out of place.

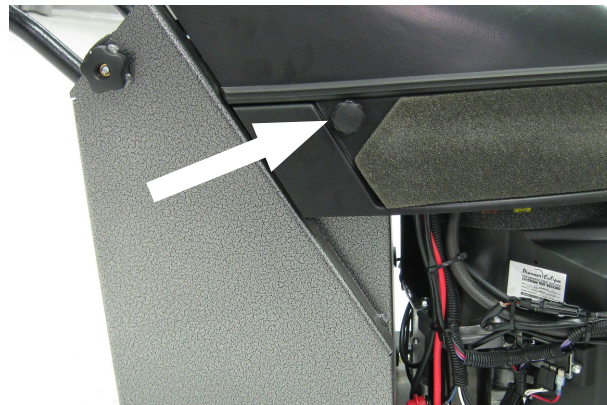

Air Filter Inspection and Replacement

1. Push machine to level surface.
2. Turn off LP cylinder and remove it.
3. Turn the two knobs 1/4 turn counter-clockwise and remove the filter cover.
4. Loosen clamp that retains filter and remove the air filter.



CAUTION! Do not wash the air cleaner filters. Do not oil the air filters. Do not use pressurized air to clean the air filters.

5. Inspect both primary and secondary air filters. If necessary, clean primary filter by lightly tapping and wipe seal ends with a clean cloth. If primary filter cannot be cleaned, is bent, or damaged, it must be replaced. (**Part #: KA110130752**) If secondary filter is dirty, do not attempt to clean it. Replace it with a new filter (**Part #: KA110137046**).
6. Check the intake hose for cracks or damage.
7. Install filters and replace cover.

Engine Dust Filter

1. The engine dust filter should be cleaned each hour and after each use by shaking out the dust and then rinsing with mild detergent. The filter can also be vacuumed with a wet-dry vacuum.
2. Squeeze out the excess water (*Do Not Wring*).
3. Allow the filter to air dry.

NOTE: Failure to maintain a clean engine filter will cause the engine to overheat. Also, it may cause the exhaust emissions to elevate to harmful levels. If necessary, replace with (**Part #: MP373400**).



Valve Clearance & Re-torque Heads

Refer to Kawasaki's FS481V service manual.

Valve Seating

Refer to Kawasaki's FS481V service manual.

Head Bolt Maintenance

Refer to Kawasaki's FS481V service manual.

Cooling Fin Maintenance

- A. Remove blower housing and any other shrouds.
- B. Clean the cooling fins as necessary using compressed air or pressure washer.
- C. Reinstall all housings and shrouds.

Inspect Fuel Hose and Connections

1. Push machine to level surface.
2. Turn off LP cylinder and remove it.
3. Remove the hood that covers the battery and regulator.
4. Inspect hoses for abrasions and other signs of wear. Replace all worn or damaged hoses.
5. Check for gas leaks by spreading a soapy water solution around all connections while the LP cylinder is reconnected and the service valve is turned ON.



5. If a leak is detected, turn off the LP cylinder. If the leak is in a hose, replace it. If the leak is at a fitting, loosen and clean it. Apply pipe-sealing compound and re-tighten it.
6. Recheck for leaks using a soapy water solution. If leaks persist at fittings, replace them and recheck with a soapy water solution once more.

Inspect Brushes / Pad Holders

1. Push machine to level surface.
2. Turn off LP cylinder and remove it.
3. Place the machine in the Rok-Bak position (see Rok-Bak section.)
4. Inspect brushes for loose bolts, cracks, and brush wear. It is recommended that brushes be replaced when bristles are worn to 1/2" (1.3cm) length.

WARNING! A damaged brush / pad holder rotating at a high rate of speed may be an extreme hazard if it should come apart.

Belt Maintenance

1. Push machine to level surface.
2. Turn off LP cylinder and remove it.
3. Place the machine in the Rok-Bak position (See "Rok-Bak & Pad Change" section).
4. Remove the Splash Plate.
5. Rotate the brushes/pad drivers and inspect the belt.
5. If cracks or excessive wear is present, the belt needs to be replaced.
6. To check for the proper tightness, squeeze the belt together. The belt should depress between 1/4" (0.6 cm) and 1/2" (1.3 cm).

Belt Replacement

APEC Part #: MP402100

- A. Push machine to a level surface.
- B. Place the machine in the Rok-Bak position (See Rok-Bak section).
- C. Remove both brushes allowing access to the pulley cover.
- D. Expose the belt by removing the pulley cover (four 1/4" screws) and the rear splash plate (two 1/4" screws).

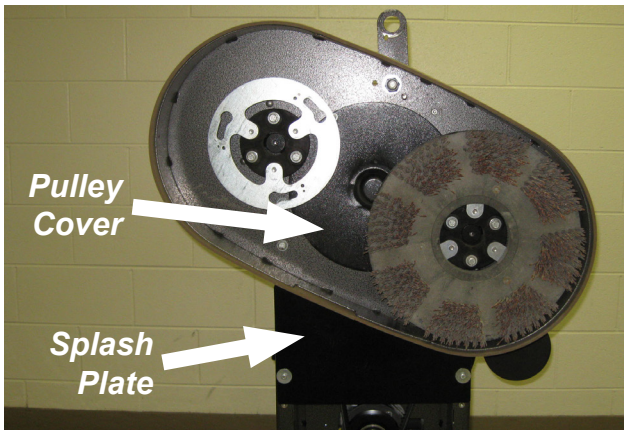

- E. Remove the belt by slipping it off the center gearbox pulley. Once the belt is off of the larger center pulley, go ahead and take the belt off of the tensioner and clutch.
- F. With the belt off, check the fasteners and condition of all the drive components.
- G. Install new belt and re-attach the rear splash plate and pulley cover.
- H. Check belt for correct operation and proper tightness.
- I. Return the machine to its operating position by lowering it back to the floor. Return the handle to the desired operating position.

Gearbox Maintenance

NOTE: Check gearbox oil level before each use. Add oil if needed.

WARNING! The drive must be filled to proper level with recommended lubricant before operation.

1. In order to drain the gearbox oil, the gearboxes need to be removed from the machine. To do this:
 - a) Remove brush assembly from output shaft.
 - b) Loosen couplings that couple the three (3) boxes together.
 - c) Loosen the pulley on the center gearbox.
 - d) Remove all retaining bolts.
 - e) Slip the boxes from the machine.
2. Remove the drain plugs (located in the sides of gearboxes) and drain the oil into a drain pan. Allow to drain completely.
3. With plug removed fill with AGMA 5EP or equivalent gear lubricant as follows:
 - 30"**: 5 oz. (14.8 ml) per box
 - 38"**: 16 oz. (47 ml) per box
4. Replace plug and retighten. Re-assemble pulley, couplings, brush assemblies, and gearboxes.
5. Dispose of used oil properly. Relubrication: Service life and efficiency of gears and bearings will be affected by oxidation or contamination of the lubricating oil. Improved performance will be obtained by periodic relubrication in accordance with the following recommendations.

After an initial operating period of approximately 500 hours or six months, the housing should be completely drained, preferably while warm. Refill housing to proper level with fresh oil.

Tire Maintenance

Tire pressure should be checked before each use. Tires should have equal pressure. The recommended tire pressure is located on the side wall of tire.

Battery Maintenance

The battery supplied with this machine is a sealed, absorbed glass mat (AGM), maintenance free type. It never needs servicing. When battery replacement is necessary (**Part #: MP362200**).

1. Push machine to level surface.
2. Turn off LP cylinder and remove it.

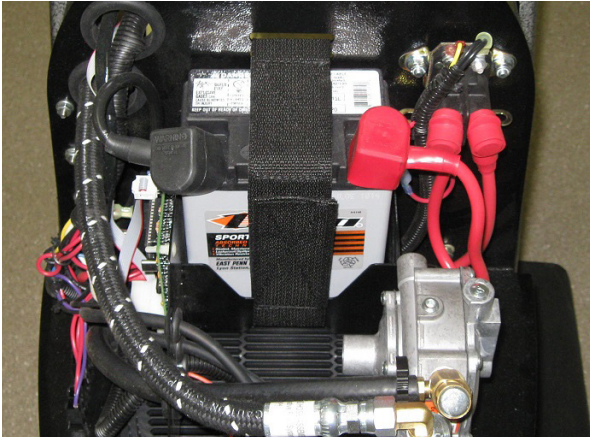

3. Remove the hood that covers the battery and regulator.
4. Disconnect the “BLACK” negative battery cable first.
5. Then disconnect the “RED” positive battery cable (**DO NOT** disconnect the “RED” cable first).
5. Loosen battery-retaining strap.
6. Lift out old battery and replace with new battery.
7. Secure battery with battery-retaining strap.
8. Connect the “RED” positive battery cable first (**DO NOT** connect the “BLACK” cable first).
9. Connect the BLACK negative battery cable.

NOTE: *Dispose of old battery in the proper manner. Most auto parts stores accept used batteries for recycling.*

PROPOSITION 65 WARNING

- Battery posts, terminals, and related accessories contain lead and lead compounds, chemicals known to the State of California to cause cancer and reproductive harm.
- Batteries also contain other chemicals known to the State of California to cause cancer.
- Wash hands after handling.

Machine Storage

Only authorized, trained personnel should have access to propane cylinders and machines.

1. Remove propane fuel cylinder when not in use and store it outside in a storage cage in accordance with NFPA Handbook 58 CAN/CGAB149.2. Do not release or bleed propane inside the building. Please consult your local Fire Marshal to ensure that you are in compliance with local fire codes.
2. Store machine away from objects that may fall and damage it.
3. Never store machine or fuel cylinders near an open flame or heat-producing device.
4. Make sure machine is cleaned properly before storing.
5. Never store machine with cylinders installed, or store spare cylinders in an enclosed van or trailer.
6. Store machine in a dry location, temperature not to exceed 120°F (50°C).

Repacking the Machine

Refer to *Unpacking* and repack the machine using original packing materials and container. Store machine in a dry location, temperature not to exceed 120°F (50°C).

Transporting the Machine

When transporting a propane powered floor machine with the fuel cylinder installed, the cylinder should be securely fastened with the service valve closed and the machine should be secured in the vehicle. Any propane fuel cylinders not installed should be securely fastened to avoid movement and damage. Never store machine with cylinder installed or store spare cylinders in an enclosed van or trailer. It is a good practice to check propane cylinders for overfilling before transporting them. If overfilled, correct before loading them in the vehicle by venting the excess propane outside in a safe area using the bleeder valve.

Machine Specifications

<u>Starting:</u>	12VDC Battery
<u>Frame / Deck:</u>	Fabricated Steel Sheet Metal
<u>Sound Level:</u>	< 89 dB(A)
<u>Vibration:</u>	Less than 2.5 m/s ²
<u>Engine:</u>	Kawasaki FS481V, 603cc Air Cooled
<u>Engine Speed:</u>	Idle - 1800-2000 rpm High Idle - 3400-3500 rpm
<u>Engine Oil:</u>	SAE 30 w/ API Service SH or SJ
<u>Engine Oil Capacity:</u>	Filter not removed - 1.6qt (1.5L) Filter removed - 1.8qt (1.7L)
<u>Engine Primary Air Filter (Paper Element):</u>	KA110130752
<u>Engine Air Pre-Cleaner (Foam Element):</u>	KA110137046
<u>Spark Plug:</u>	KA920702112
<u>Spark Plug Gap:</u>	0.025 in. (0.635 mm)
<u>LP Cylinder Type:</u>	20lb (9.1 kg) Vapor Withdraw
<u>Gearbox Oil Type:</u>	AGMA 5EP

30" Machines

Pad Size:	2 X 16" (40.6 cm)
Pad Speed:	325 RPM
Width:	32.6" (82.8 cm)
Length:	62.4" (158.5 cm)
Height:	44.75" (113.7 cm)
Weight:	365 lbs (<i>w/o cylinder</i>) (165.6 kg)

38" Machines

Pad Size:	2 X 20" (51 cm)
Pad Speed:	325 RPM
Width:	40.25" (102.2 cm)
Length:	65.50" (166.4 cm)
Height:	44.75" (113.7 cm)
Weight:	435 lbs (<i>w/o cylinder</i>) (197.3 kg)

PE440ST

Propane Stripping Machine

Parts Manual

Notes:

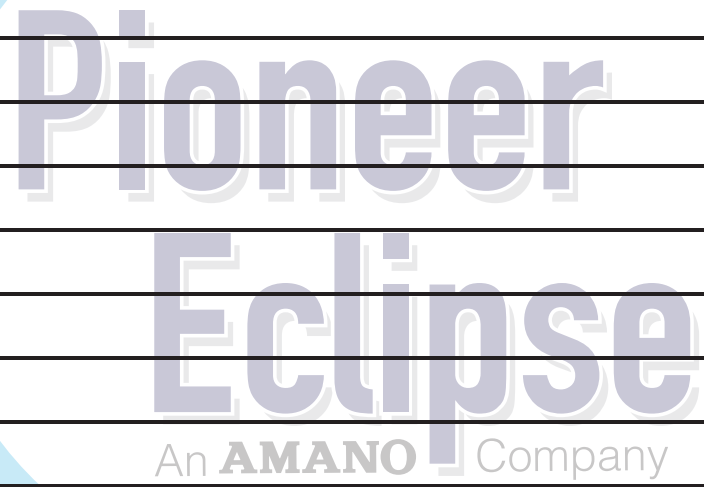

Electrical Schematic (with SafeSense)

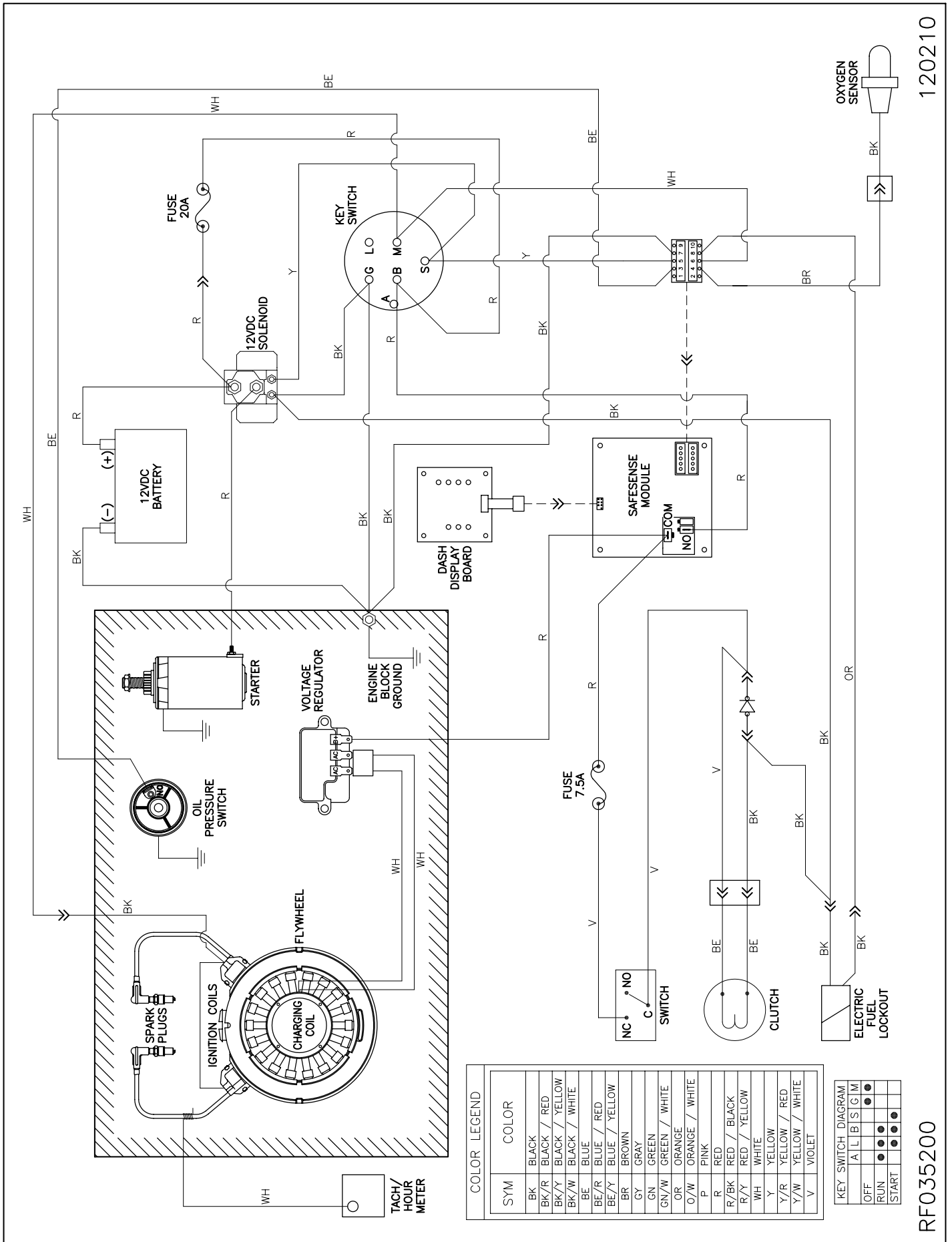

COLOR LEGEND

SYM	COLOR
BK	BLACK
BK/R	BLACK / RED
BK/Y	BLACK / YELLOW
BK/W	BLACK / WHITE
BE	BLUE
BE/R	BLUE / RED
BE/Y	BLUE / YELLOW
BR	BROWN
GY	GRAY
GN	GREEN
GN/W	GREEN / WHITE
OR	ORANGE
O/W	ORANGE / WHITE
P	PINK
R	RED
R/BK	RED / BLACK
R/Y	RED / YELLOW
WH	WHITE
Y	YELLOW
Y/R	YELLOW / RED
Y/W	YELLOW / WHITE
V	VIOLET

KEY SWITCH DIAGRAM

	A	L	B	S	G	M
OFF						
RUN	●					
START	●	●	●	●	●	●

RF035200

120210

Electrical Schematic (with Optional SafeStop)

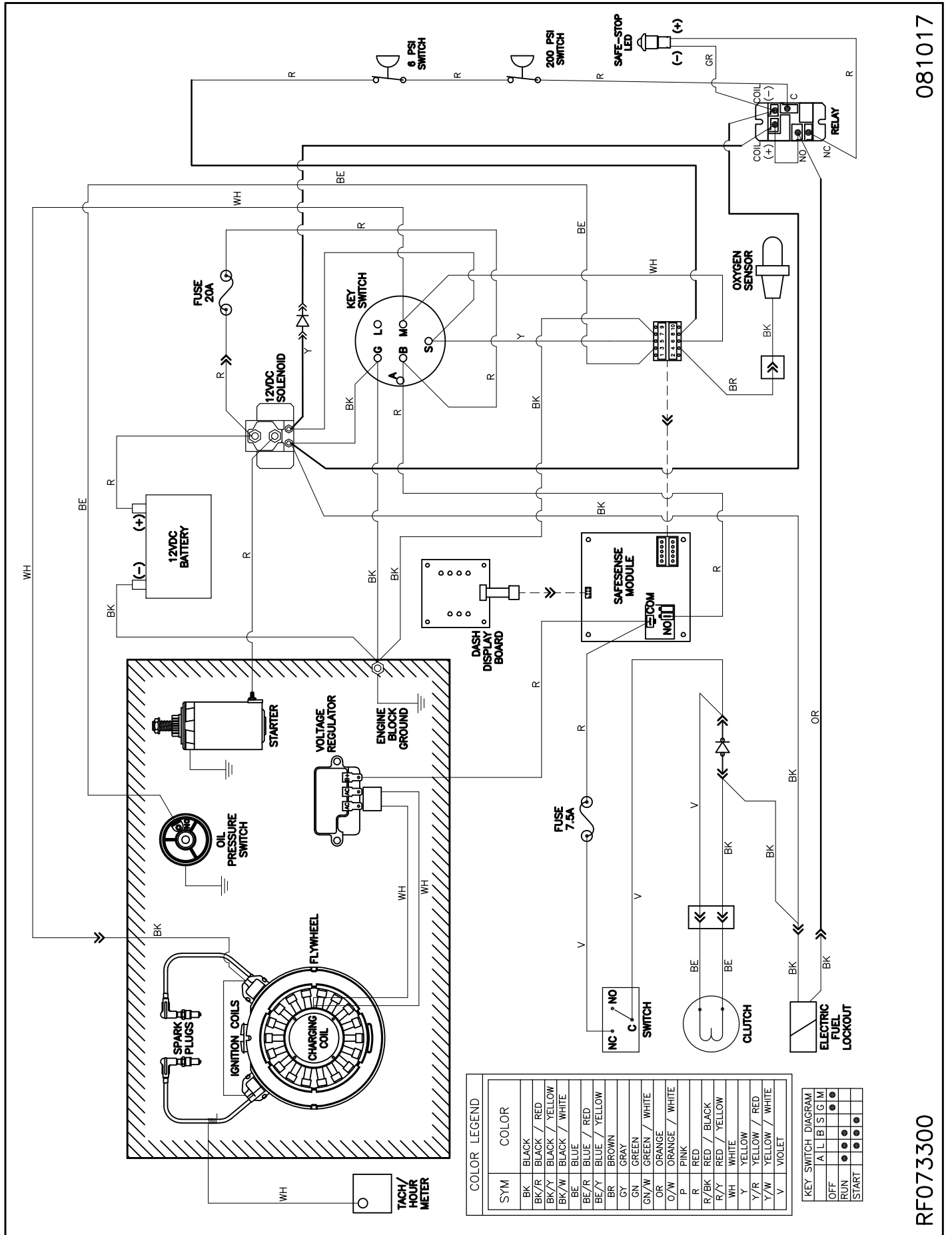

COLOR LEGEND

SYM	COLOR
BK	BLACK
BK/R	BLACK / RED
BK/Y	BLACK / YELLOW
BK/W	BLACK / WHITE
BE	BLUE
BE/R	BLUE / RED
BE/Y	BLUE / YELLOW
BR	BROWN
GY	GRAY
GN	GREEN
GN/W	GREEN / WHITE
OR	ORANGE
O/W	ORANGE / WHITE
P	PINK
R	RED
R/BK	RED / BLACK
R/Y	RED / YELLOW
WH	WHITE
Y	YELLOW
Y/R	YELLOW / RED
Y/W	YELLOW / WHITE
V	VIOLET

KEY SWITCH DIAGRAM

	A	L	B	S	G	M
OFF	●	●	●	●	●	●
RUN	●	●	●	●	●	●
START	●	●	●	●	●	●

081017

RF073300

Electrical Schematic (without SafeSense)

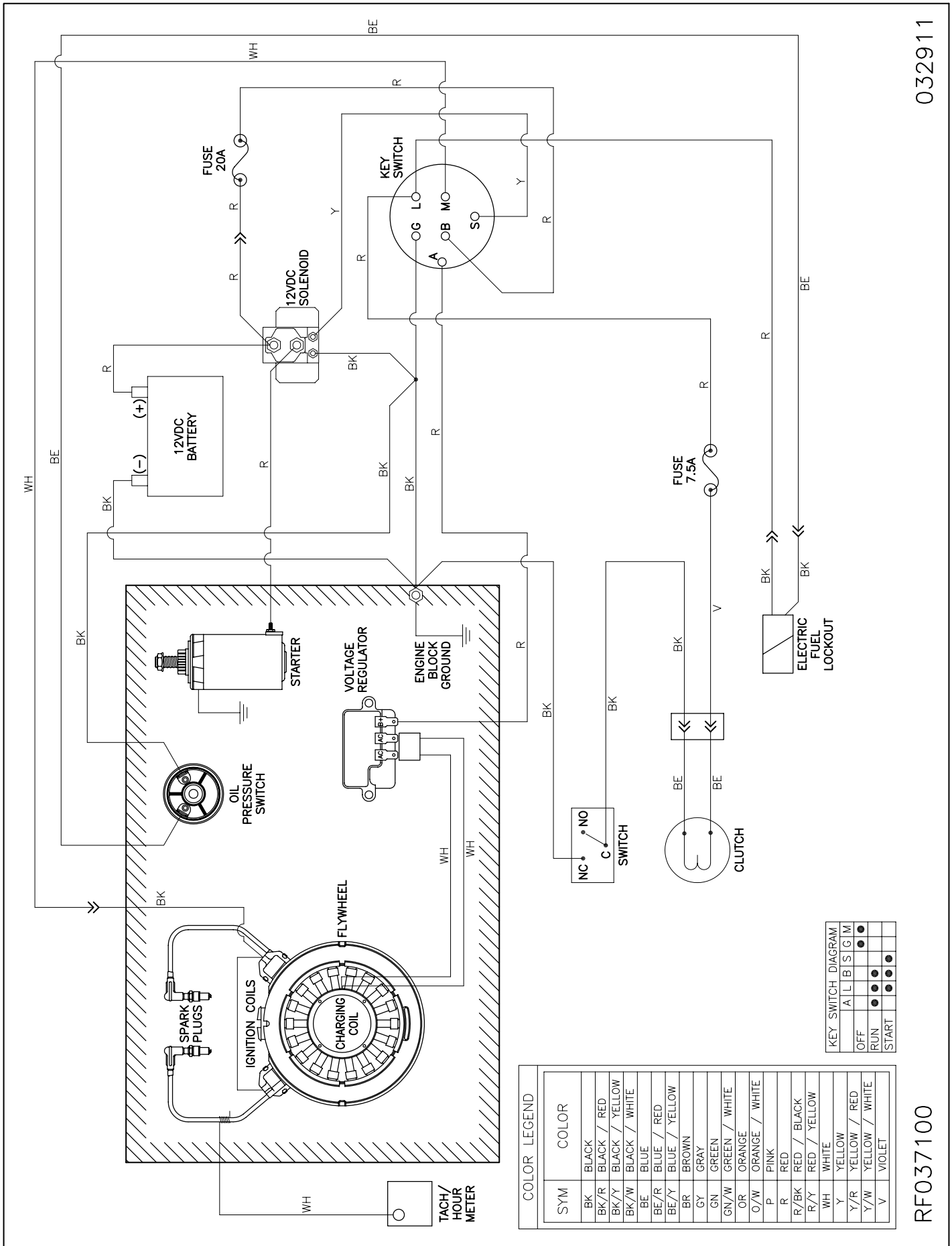

SYM	COLOR
BK	BLACK
BK/R	BLACK / RED
BK/Y	BLACK / YELLOW
BK/W	BLACK / WHITE
BE	BLUE
BE/R	BLUE / RED
BE/Y	BLUE / YELLOW
BR	BROWN
GY	GRAY
GN	GREEN
GN/W	GREEN / WHITE
OR	ORANGE
O/W	ORANGE / WHITE
P	PINK
R	RED
R/BK	RED / BLACK
R/Y	RED / YELLOW
WH	WHITE
Y	YELLOW
Y/R	YELLOW / RED
Y/W	YELLOW / WHITE
V	VIOLET

KEY SWITCH DIAGRAM	A	L	B	S	G	M
	OFF					
RUN	●					
START		●				

RF037100

032911

Connections - with SafeSense

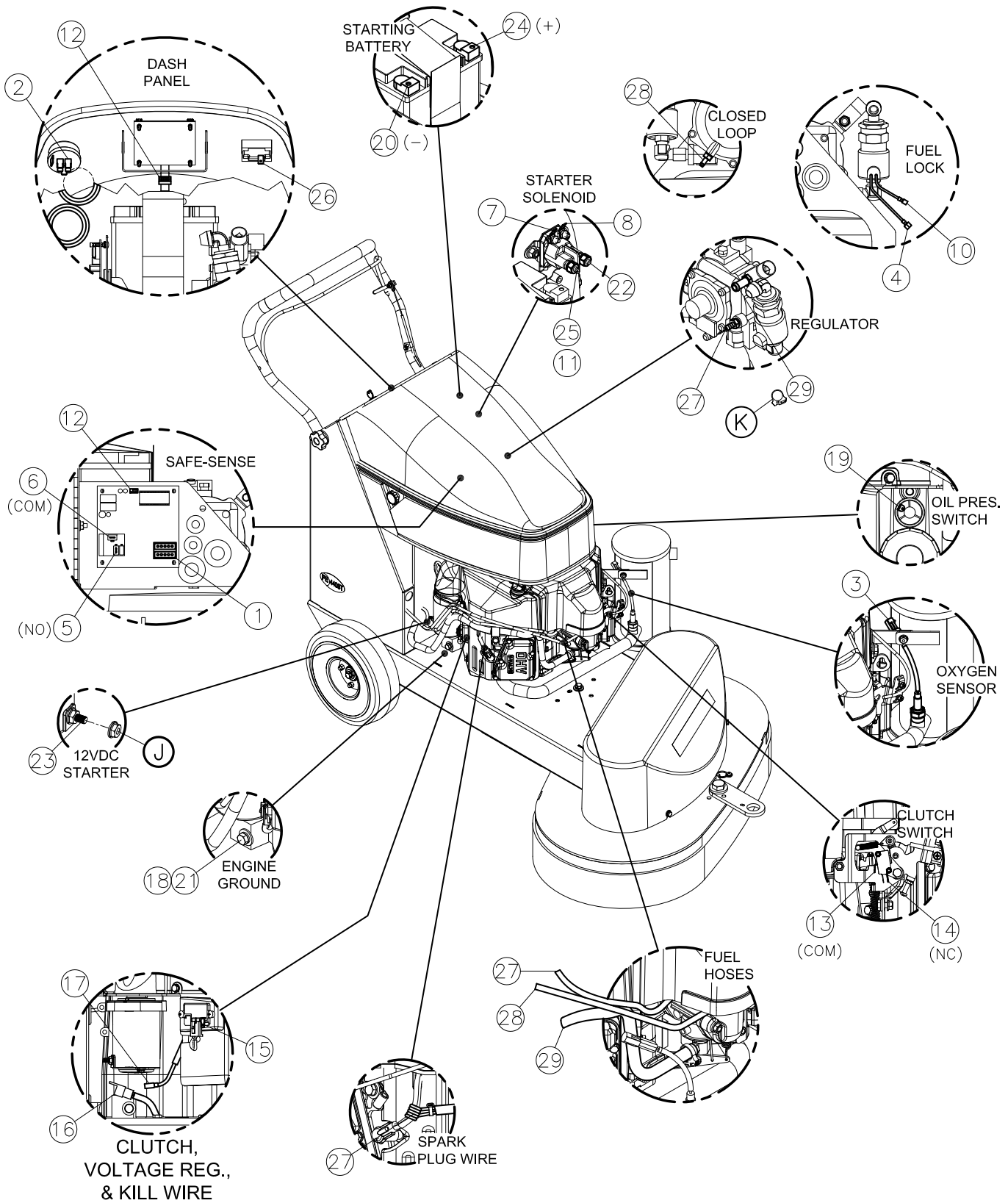

RF037400

020116

Connections - with SafeSense (Continued)

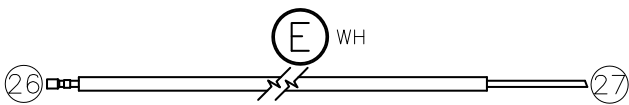
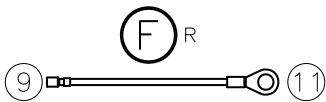
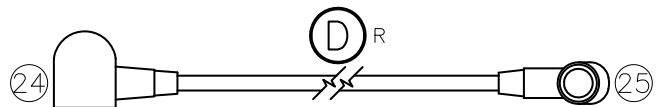
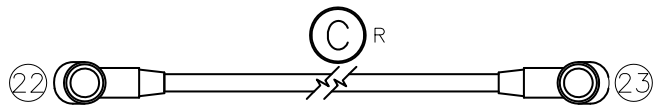
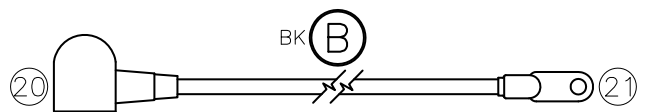
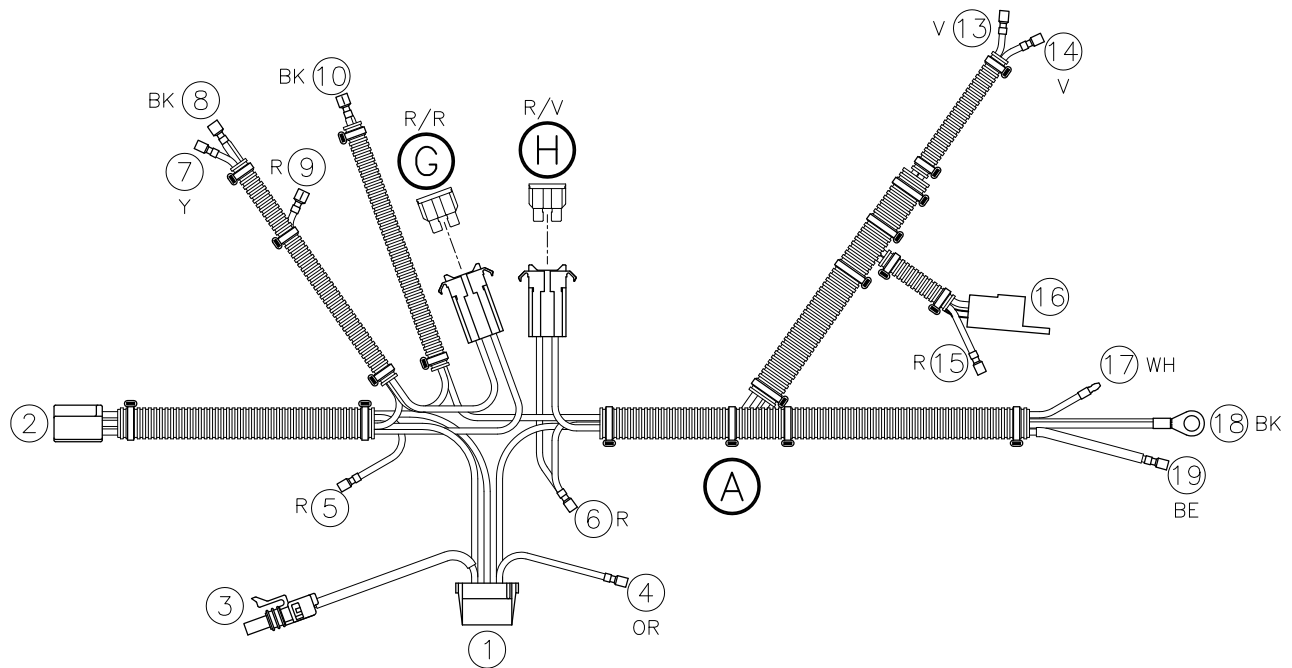

RF037400

020116

Item	Ref. No.	Description	Qty	Item	Ref. No.	Description	Qty
A	MP379200	HARNESS, WIRING	1	F	MP354900	WIRE, SOLENOID, BATTERY	1
B	MP2012	CABLE, BATTERY, NEG	1	G	SS2570	FUSE, 20A	1
C	MP379400	CABLE, BATTERY, POS., 34"	1	H	MP043000	FUSE, 7.5A	1
D	MP379500	CABLE, BATTERY, POS., 14"	1	J	NB9545	NUT, FLANGE, 1/4"	1
E	MP392200	HARNESS, TACH/HOUR, 51"	1	K	NB7282	CLAMP, HOSE	1

Connections - with SafeStop

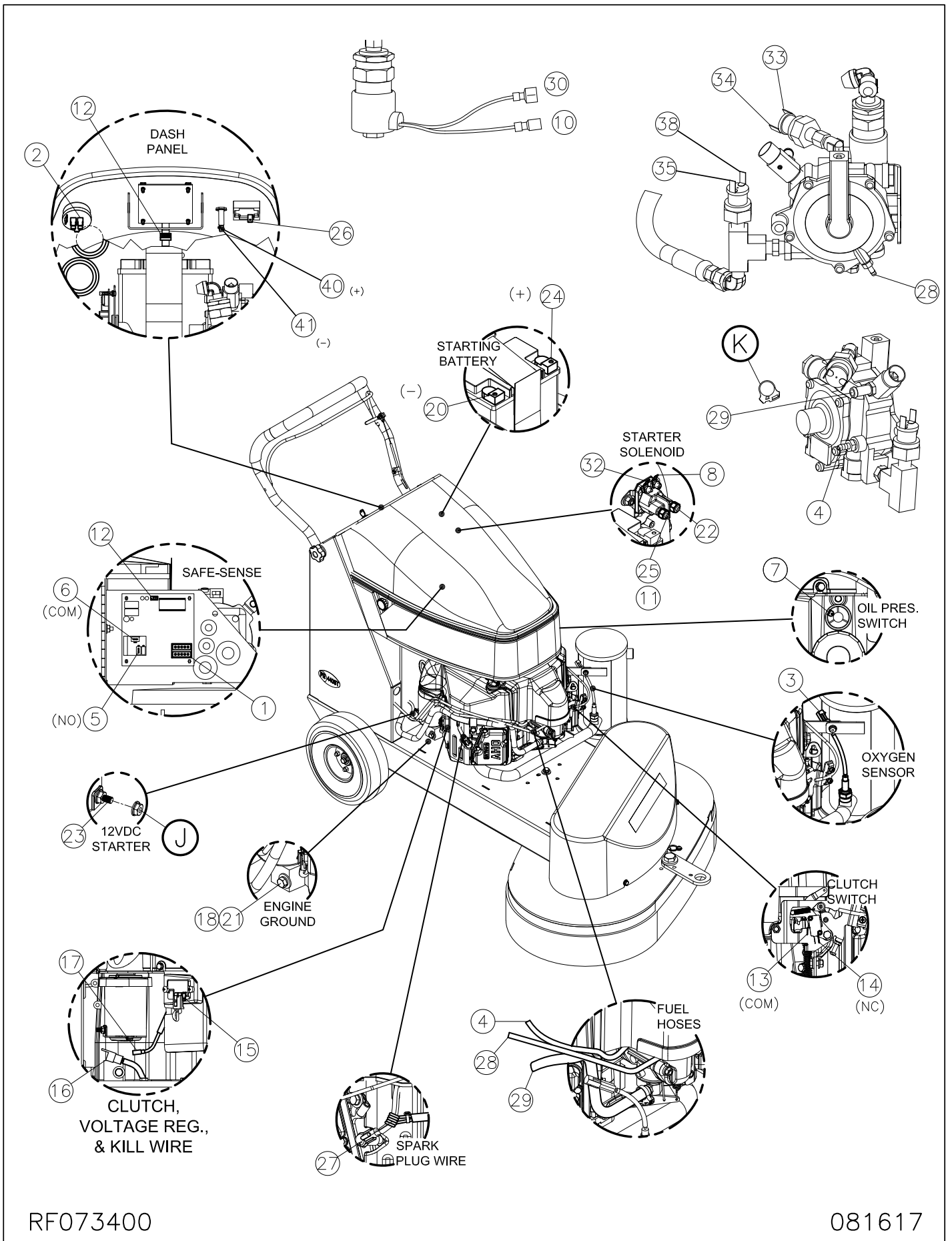

RF073400

081617

Connections - with SafeStop (continued)

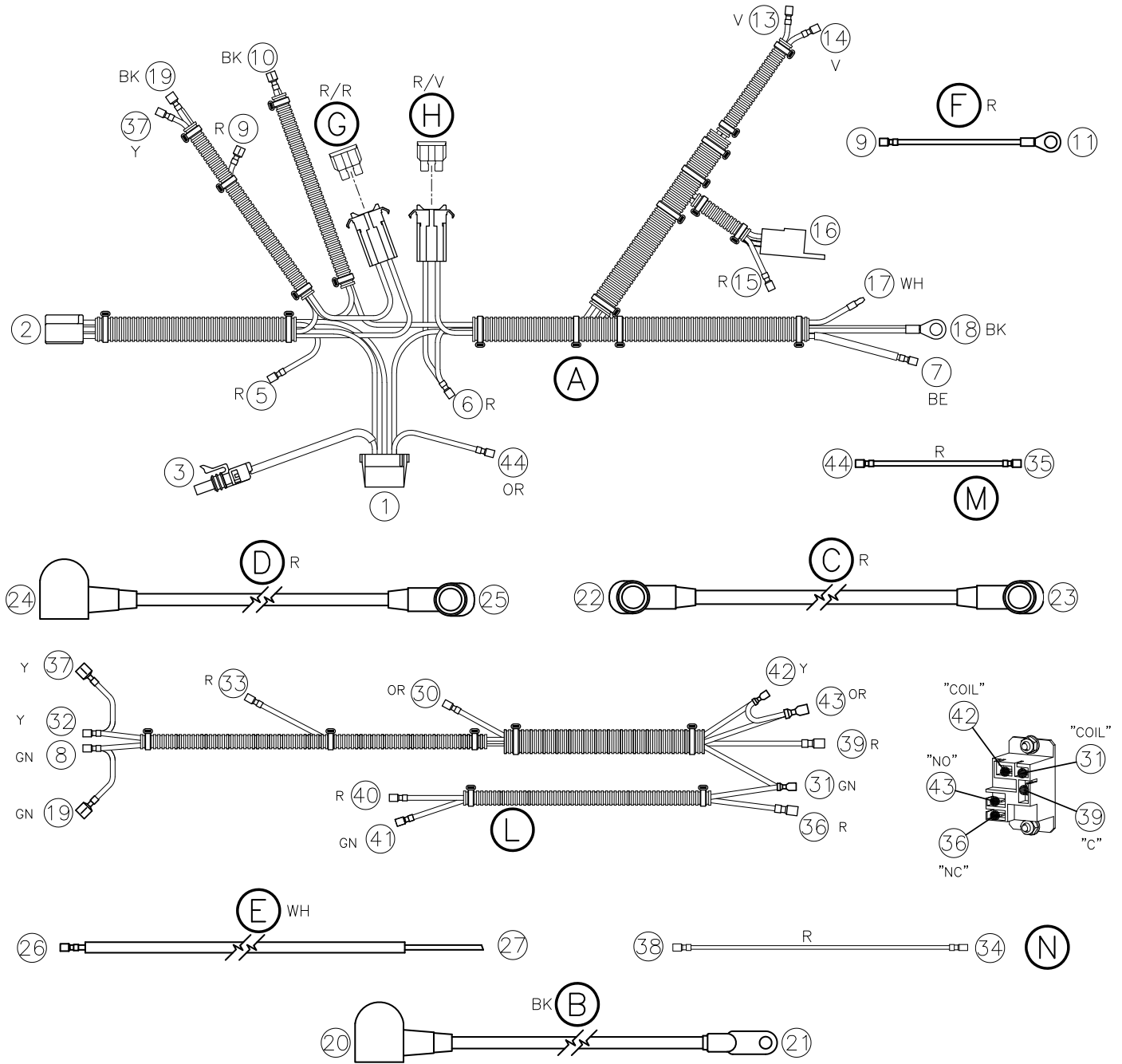

RF073401

081617

ITEM NO.	PART NO.	DESCRIPTION	QTY.
A	MP379200	HARNESS, WIRING, BLKHD, w/ SAFE	1
B	MP2012	CABLE, BATTERY, NEGATIVE	1
C	MP379400	CABLE, BATTERY, POS., SM BOOT, 34"	1
D	MP379500	CABLE, BATTERY, POS., LEFT BOOT, 14"	1
E	MP392200	HARNESS, TACH/HOUR, 51"	1
F	MP354900	WIRE, SOLENOID, BATTERY	1
G	SS2570	FUSE, 20 AMP, ATO	1
			1

ITEM NO.	PART NO.	DESCRIPTION	QTY.
H	MP043000	FUSE, 7.5 AMP, ATO	1
J	NB9545	NUT, SPIN LOCK, 1/4-20	1
K	NB7282	CLAMP, HOSE, NO.38	1
L	MP522400	HARNESS, SAFESTOP, 440ST	1
M	MP510300	WIRE, JUMPER, RED, 7.25"	1
N	MP510400	WIRE, JUMPER, RED, 8.5"	1

Connections - without SafeSense

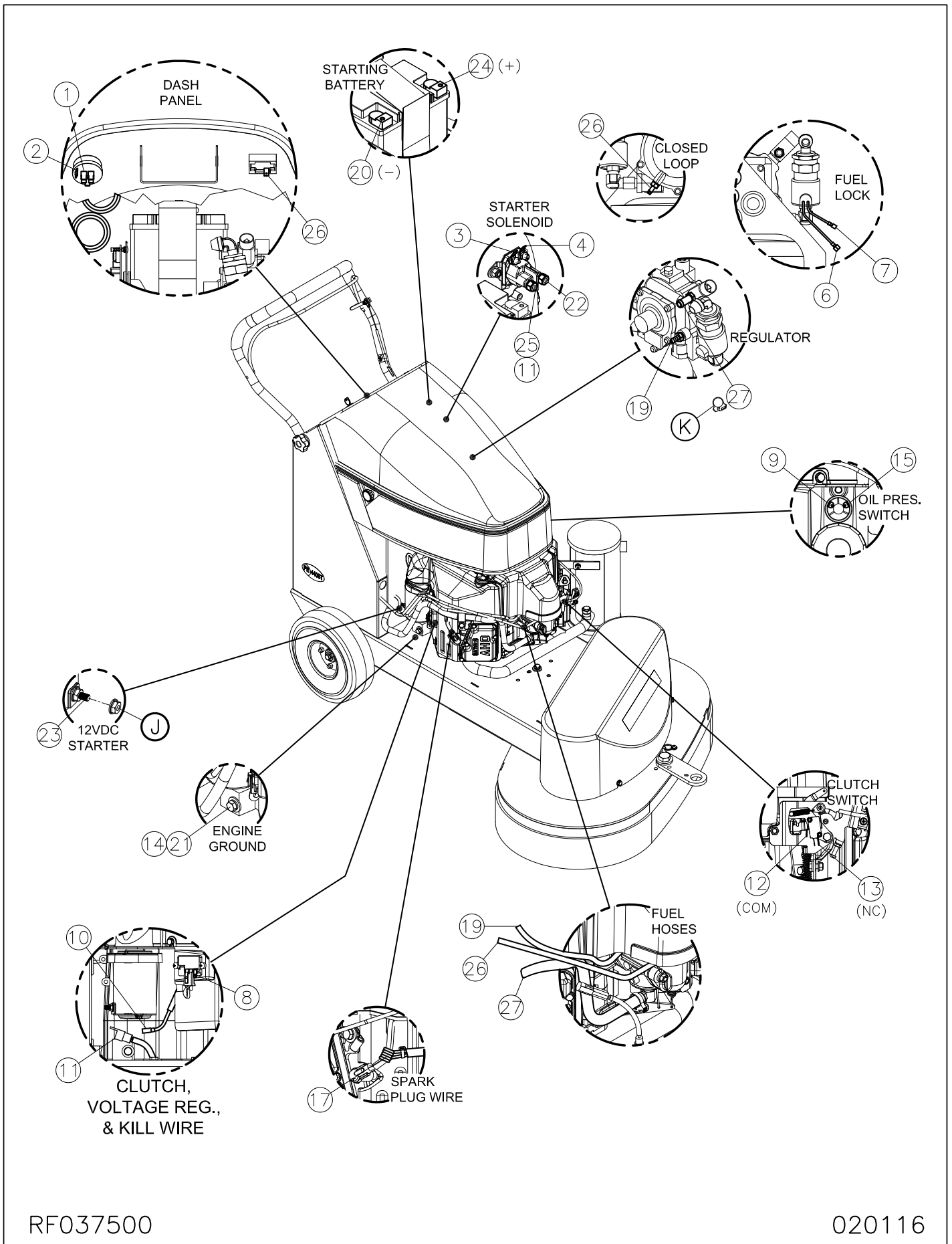

RF037500

020116

Connections - without SafeSense (Continued)

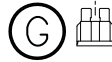
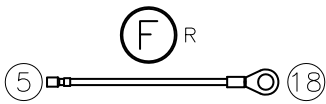
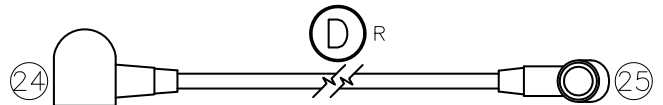
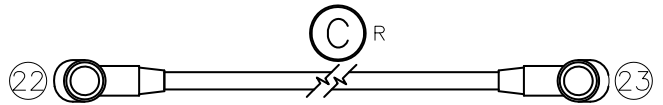
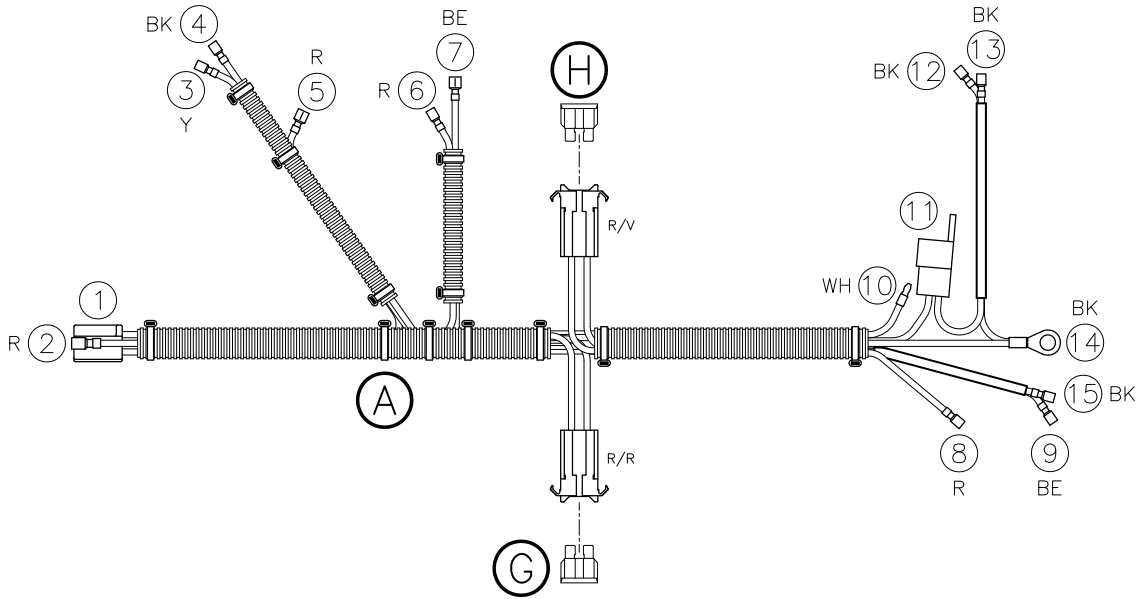

RF037500

020116

Item	Ref. No.	Description	Qty	Item	Ref. No.	Description	Qty
A	MP392300	HARNESS, WIRING	1	F	MP354900	WIRE, SOLENOID, BATTERY	1
B	MP2012	CABLE, BATTERY, NEG	1	G	SS2570	FUSE, 20A	1
C	MP379400	CABLE, BATTERY, POS., 34"	1	H	MP043000	FUSE, 7.5A	1
D	MP379500	CABLE, BATTERY, POS., 14"	1	J	NB9545	NUT, FLANGE, 1/4"	1
E	MP392200	HARNESS, TACH/HOUR, 51"	1	K	NB7282	CLAMP, HOSE	1

Engine Assembly

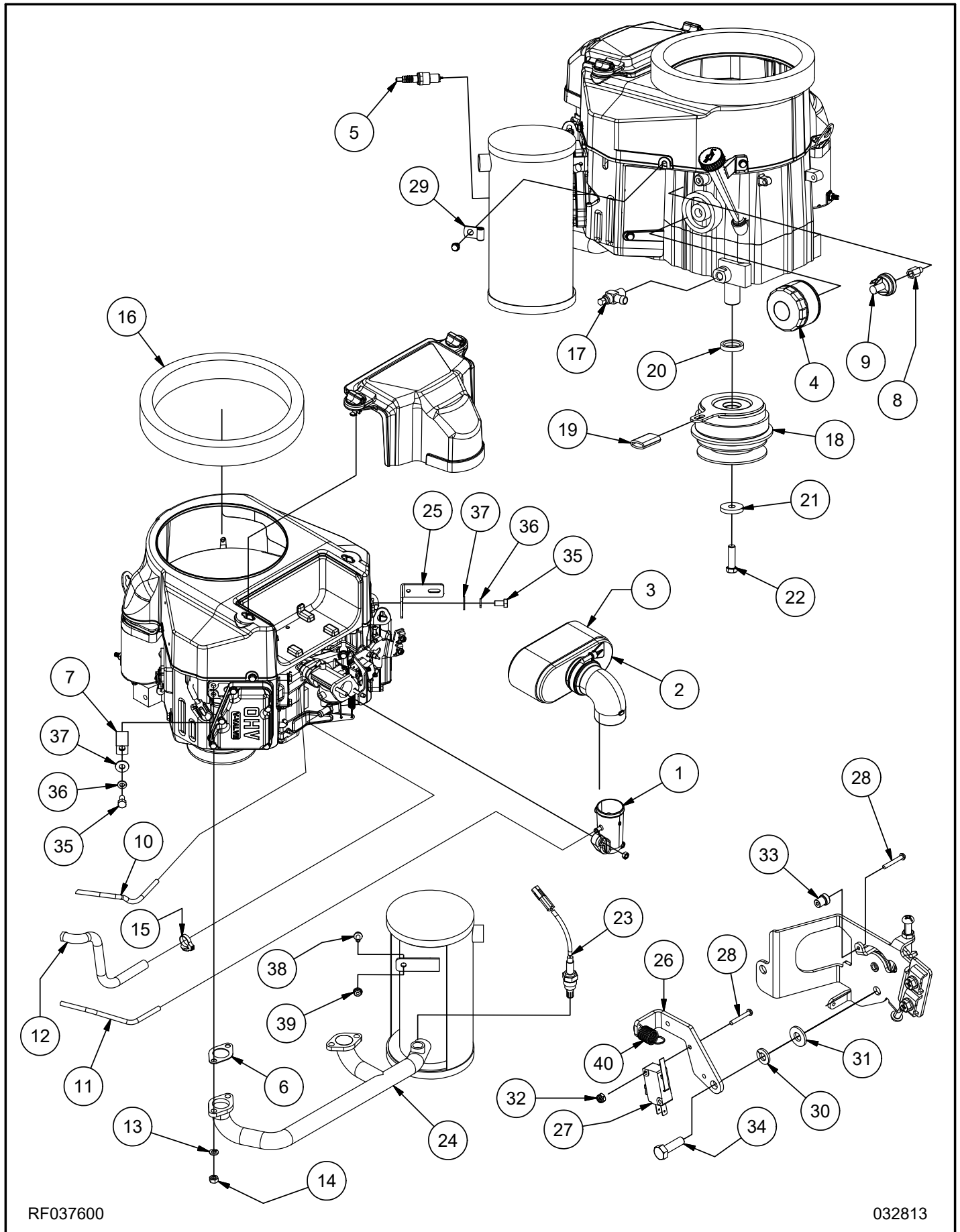

RF037600

032813

Engine Assembly (continued)

<u>Item</u>	<u>Ref. No.</u>	<u>Description</u>	<u>Qty</u>	<u>Item</u>	<u>Ref. No.</u>	<u>Description</u>	<u>Qty</u>
1	KA160600742	PIPE, INTAKE	1	21	MP4805	SPACER, BOTTOM, CLUTCH	1
2	KA110130752	ELEMENT, FILTER, AIR	1	22	NB005800	BOLT, HEX, 7/16" X 1-1/2"	1
3	KA110137046	PRECLEANER, AIR	1	23A	MP466500	SENSOR, OXYGEN (w/ Sf Snse)	1
4	KA490657007	FILTER, OIL	1	23B	MP015200	PLUG, SENSOR (w/o Sf Snse)	1
5	KA920702112	PLUG, SPARK, NGK, BPR4ES	1	24	MP365300	MUFFLER, CATALYST, VERT.	1
6	KA110607016	GASKET, MUFFLER	2	25	MP387601	BRACKET, MUFFLER	1
7	NB8130	CLAMP, 3/4" ID	1	26	MP452101	BRACKET, SWITCH	1
8	MP044800	ADAPTER, 1/8" NPT	1	27	MP318400	SWITCH, MICRO, 12V	1
9A	MP028700	SWITCH, OIL, SP (w/ Sf Snse)	1	28	NB9625	SCREW, #4 X 3/4"	3
9B	MP019200	SWITCH, OIL, DP (w/o Sf Snse)	1	29	NB8125	CLAMP, 1/4"	1
10	NB2460	HOSE, VACUUM, 5/32"	37"	30	NB6110	WASHER, LOCK, 1/4"	1
11	NB2460	HOSE, VACUUM, 5/32"	45"	31	NB3350	WASHER, FLAT, 1/4"	1
12	NB2470	HOSE, FUEL, 3/8"	40"	32	NB007000	NUT, LOCK, #4	2
13	KA461DA0800	WASHER, LOCK, M8	4	33	MP452200	SPACER, THROTTLE, #4	1
14	KA922107027	NUT, HEX, M8	4	34	NB6012	BOLT, HEX, M6 X 20	1
15	NB7282	CLAMP, HOSE	1	35	NB065000	BOLT, HEX, M8 X 16	2
16	MP043100	SEAL, INTAKE, AIR	1	36	NB6111	WASHER, LOCK, 5/16"	2
17	MP072300	VALVE, DRAIN, OIL	1	37	NB9267	WASHER, FLAT, 5/16"	2
18	MP4787	CLUTCH, ASM.	1	38	NB049300	SCREW, 1/4" X 1/2"	1
19	MP4790	TUBING, NEOPRENE	2"	39	NB9545	NUT, FLANGE, 1/4"	1
20	MP371700	SPACER, 1.02" ID	1	40	MP452300	SPRING, EXTENSION	1

Frame Assembly

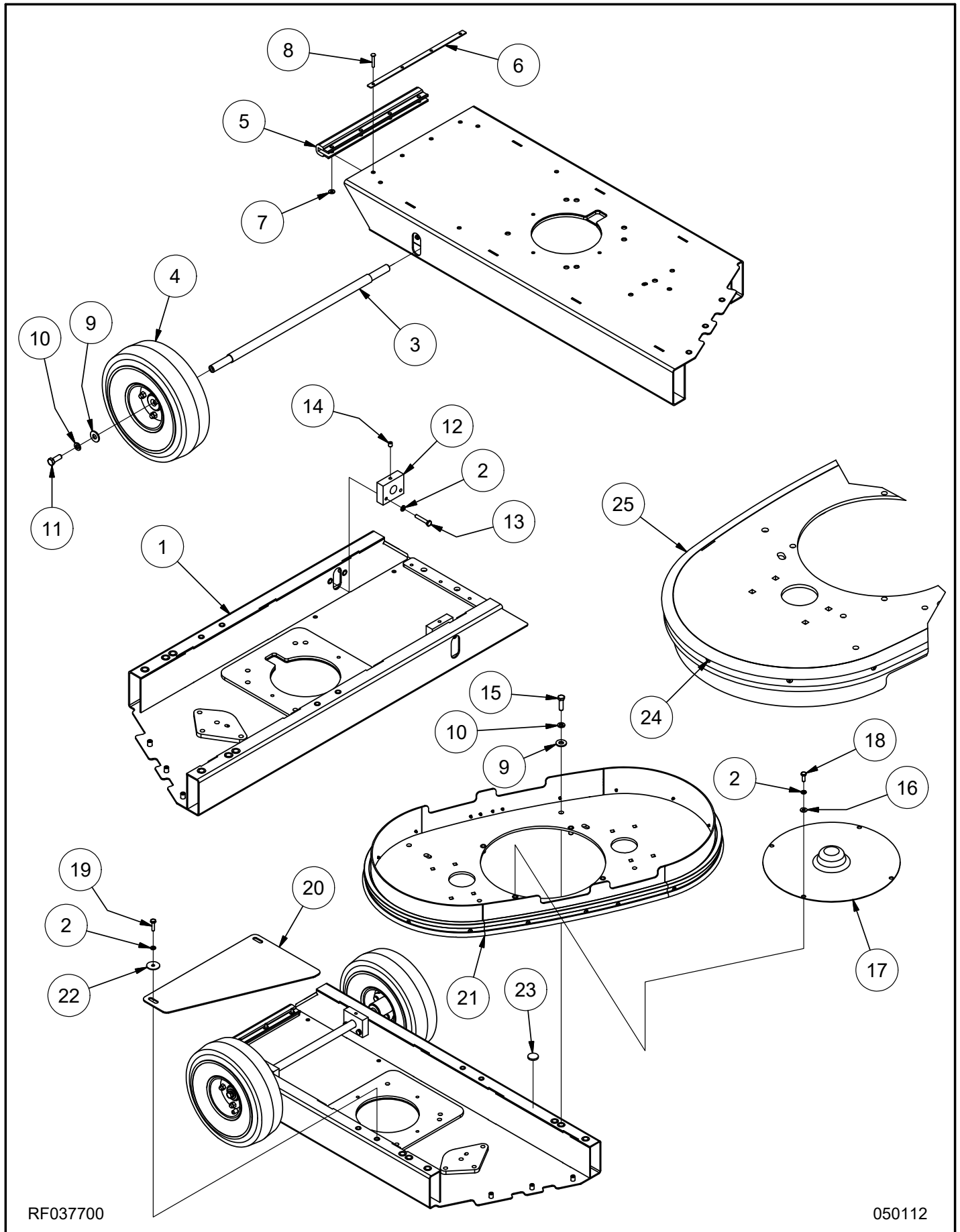

RF037700

050112

Frame Assembly (continued)

<u>Item</u>	<u>Ref. No.</u>	<u>Description</u>	<u>Qty</u>	<u>Item</u>	<u>Ref. No.</u>	<u>Description</u>	<u>Qty</u>
1	MP391300	FRAME, ASM.	1	15	NB6044	BOLT, HEX, 3/8" X 1-1/4"	4
2	NB6110	WASHER, LOCK, 1/4"	10	16	NB3350	WASHER, FLAT, 1/4"	4
3	BA001300	AXLE	1	17	BA014801	COVER, PULLEY	1
4	SS1315	WHEEL, 10"	2	18	NB019100	BOLT, HEX, 1/4" X 3/4"	4
5	MP371400	BUMPER, ROK-BAK	1	19	NB6530	BOLT, HEX, 1/4" X 1"	2
6	MP336200	STRAP, BUMPER	1	20	MP388801	PLATE, GUARD, SPLASH	1
7	NB9645	WASHER, FLAT, #10	4	21A	MP391600	DECK, 30", ASM.	1
8	NB063400	RIVET, 3/16" X 1"	4	21B	MP391700	DECK, 38", ASM.	1
9	NB3450	WASHER, FLAT, 3/8"	6	22	NB006400	WASHER, FENDER, 1/4"	2
10	MX1075	WASHER, LOCK, 3/8"	6	23	MP140000	FELT, DOT	1
11	NB6042	BOLT, HEX, 3/8" X 1"	2	24A	NB008900	RIVET, 3/16" (30")	18
12	BA018700	BLOCK, AXLE	2	24B	NB008900	RIVET, 3/16" (38")	20
13	NB9000	BOLT, HEX, 1/4" X 1-1/2"	4	25A	MP031805	BUMPER, SHROUD (30")	7.5 FT
14	NB2463	SCREW, SET, 5/16" X 3/8"	2	25B	MP031805	BUMPER, SHROUD (38")	9.25 FT

Bulkhead Assembly

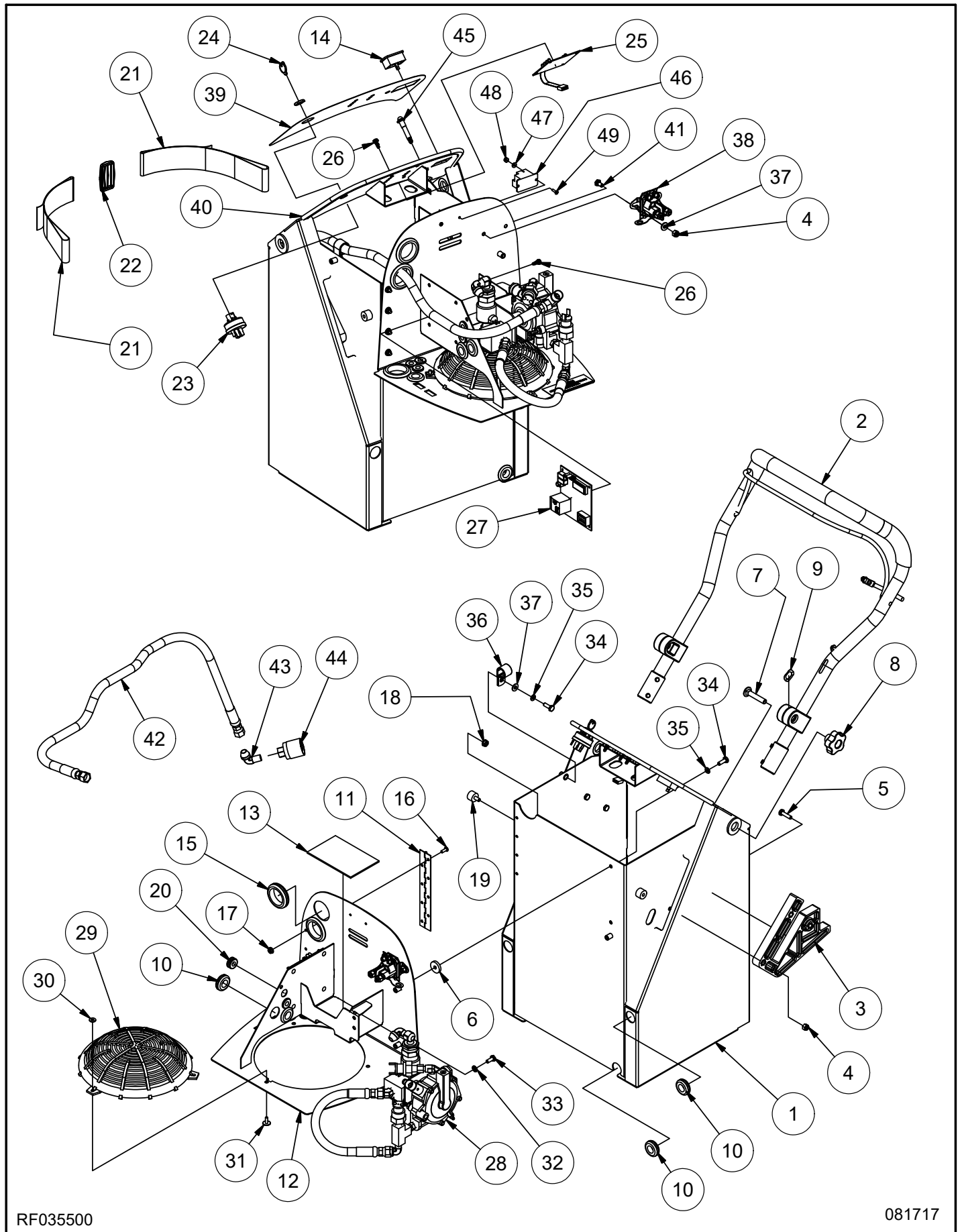

RF035500

081717

Bulkhead Assembly (continued)

<u>Item</u>	<u>Ref. No.</u>	<u>Description</u>	<u>Qty</u>	<u>Item</u>	<u>Ref. No.</u>	<u>Description</u>	<u>Qty</u>
1	MP374600	BULKHEAD, ASM.	1	24	KC4834001	KEY, SWITCH, IGNITION	1
2	MP375500	HANDLE, ASM.	1	25	MP042800	BOARD, DISPLAY***	1
3	MP039300	PLATE, LOCK, HANDLE	2	26	NB012500	SPACER, BOARD***	8
4	NB3275	NUT, LOCK, 1/4"	8	27	MP161200	MODULE, SAFESENSE***	1
5	NB6530	BOLT, HEX, 1/4" X 1"	6	28A	MP375600	REGULATOR, ASM.	1
6	MP373100	WASHER, RUBBER	2	28B	MP522100	REGULATOR, ASM. (SafeStop equipped)	1
7	NB010100	BOLT, CARRIAGE, 3/8" X 2"	2	29	KA550200900	GUARD, SCREEN, FS481V	1
8	RV005100	KNOB, HANDLE	2	30	NB9645	WASHER, FLAT, #10	3
9	NB011400	WASHER, WAVE	2	31	NB021000	RIVET, 3/16"	3
10	NB009900	GROMMET, 11/16" ID	5	32	MX1115	WASHER, STAR, 1/4"	2
11	MP373600	HINGE, 7.5" X 1.25"	1	33	NB003200	BOLT, HEX, 1/4" X 5/8"	2
12	MP374700	TRAY, BATTERY, ASM.	1	34	NB019100	BOLT, HEX, 1/4" X 3/4"	4
13	MP373800	PAD, BATTERY	1	35	NB6110	WASHER, LOCK, 1/4"	4
14	MP280400	METER, HOUR / TACH	1	36	NB8130	CLAMP, 3/4"	2
15	NB6514	GROMMET, 1-1/2" ID	3	37	NB3350	WASHER, FLAT, 1/4"	4
16	NB034100	SCREW, #10 X 1/2"	8	38	MP367100	SOLENOID, STARTER, 12V	1
17	NB9510	NUT, FLANGE, #10	8	39A	MP500500	DECAL, C.PANEL (w/ SfSnse)	1
18	NB9845	NUT, KEPS, 1/4"	2	39B	MP500400	DECAL, C.PANEL (w/o SfSense)	1
19	IN3510	MOUNT, TYPE S, 1/4"	2	40	IN1015	TRIM, BATTERY TRAY	2 FT
20	NB009800	GROMMET, 3/8" ID	5	41	NB015700	BOLT, HEX, 1/4" X 5/8"	2
21	MP368100	STRAP, 2" X 23"	2	42	MP373300	HOSE, FUEL, LP, 3/4", ASM.	1
22	MP367600	SLIDE, STRAP, 2"	1	43	MP4330	FITTING, ELBOW	1
23	MP199000	SWITCH, IGNITION	1	44	MP4500	COUPLER, REGO	1
				45	MP492000	LIGHT, RED, LED, 12V (SafeStop equipped)	1
				46	MP151500	RELAY (SafeStop equipped)	1
				47	NB007100	WASHER, FLAT, #6 (SafeStop equipped)	1
				48	NB020800	NUT, LOCK, NYLON, 6-32 (SafeStop equipped)	1
				49	NB9515	SCREW, PAN HD, 6-32 X 1/2 (SafeStop equipped)	1

*** **NOTE:** Only used on models equipped with SafeSense.

Main Assembly

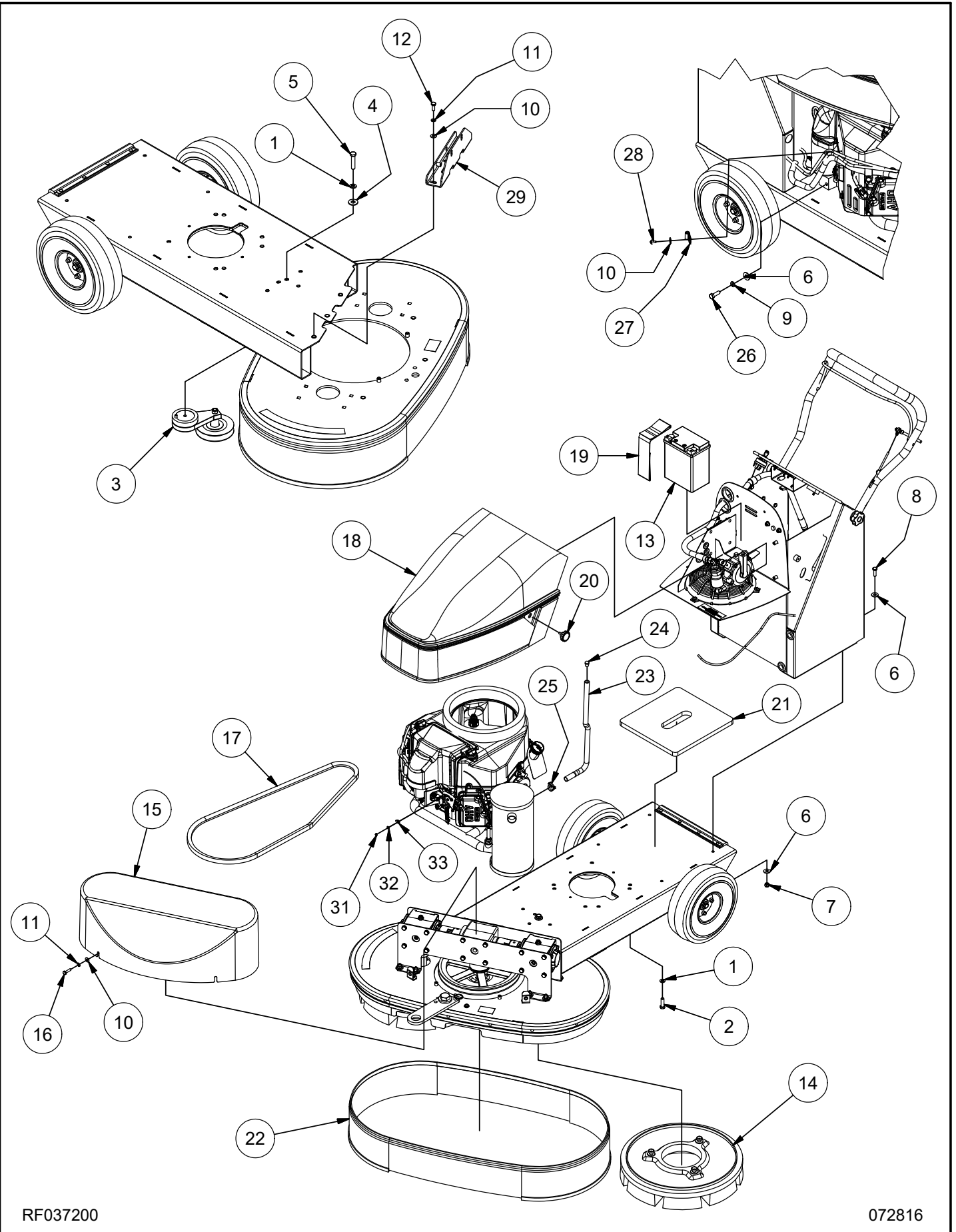

RF037200

072816

Main Assembly (continued)

<u>Item</u>	<u>Ref. No.</u>	<u>Description</u>	<u>Qty</u>	<u>Item</u>	<u>Ref. No.</u>	<u>Description</u>	<u>Qty</u>
1	MX1075	WASHER, LOCK, 3/8"	5	16	NB6530	BOLT, HEX, 1/4" X 1"	3
2	NB6044	BOLT, HEX, 3/8" X 1-1/4"	4	17	MP402100	BELT, BX-62	1
3	MP071800	TENSIONER, BELT	1	18	MP375800	HOOD, ASM.	1
4	NB3450	WASHER, FLAT, 3/8"	1	19	MP368100	STRAP, 2" X 23"	1
5	NB024500	BOLT, HEX, 3/8" X 1-3/4"	1	20	MP372600	KNOB, 1/4"	2
6	NB9267	WASHER, FLAT, 5/16"	9	21	MP470300	PAD, TANK	1
7	NB3265	NUT, LOCK, 5/16"	4	22A	BA014500	SKIRT, SPLASH (30")	1
8	NB6545	BOLT, HEX, 5/16" X 1"	4	22B	BA014700	SKIRT, SPLASH (38")	1
9	NB6111	WASHER, LOCK, 5/16"	1	23	MP4515	TUBING, OIL DRAIN	20"
10	NB3350	WASHER, FLAT, 1/4"	7	24	NB1621	PLUG, TUBING	1
11	NB6110	WASHER, LOCK, 1/4"	6	25	NB7282	CLAMP, HOSE, 3/8"	1
12	NB019100	BOLT, HEX, 1/4" X 3/4"	3	26	NB065100	BOLT, HEX, M8 X 25MM	1
13	MP362200	BATTERY, 12V	1	27	NB8125	CLAMP, HOSE, 1/4"	1
14A	BA013000	BRUSH, 16" (30")	2	28	NB064900	SCREW, #10 X 1/2"	1
14B	BA013500	PAD HOLDER, 16" (OPTIONAL)	2	29A	MP391400	BRACE, GEARBOX (30")	1
14C	BA012800	BRUSH, 20" (38")	2	29B	MP391500	BRACE, GEARBOX (38")	1
14D	BA013700	PAD HOLDER, 20" (OPTIONAL)	2	30	MP105900	CYLINDER, LP (NOT SHOWN)	1
14E	MP8505	RETAINER, PAD (PAD HOLDER)	1	31	NB007000	NUT, LOCK, #4	1
15A	BA018100	COVER, GEARBOX (30")	1	32	NB007100	WASHER, FLAT, #6	1
15B	BA017700	COVER, GEARBOX (38")	1	33	NB012300	WASHER, LINKAGE	1

Main Assembly - Deck

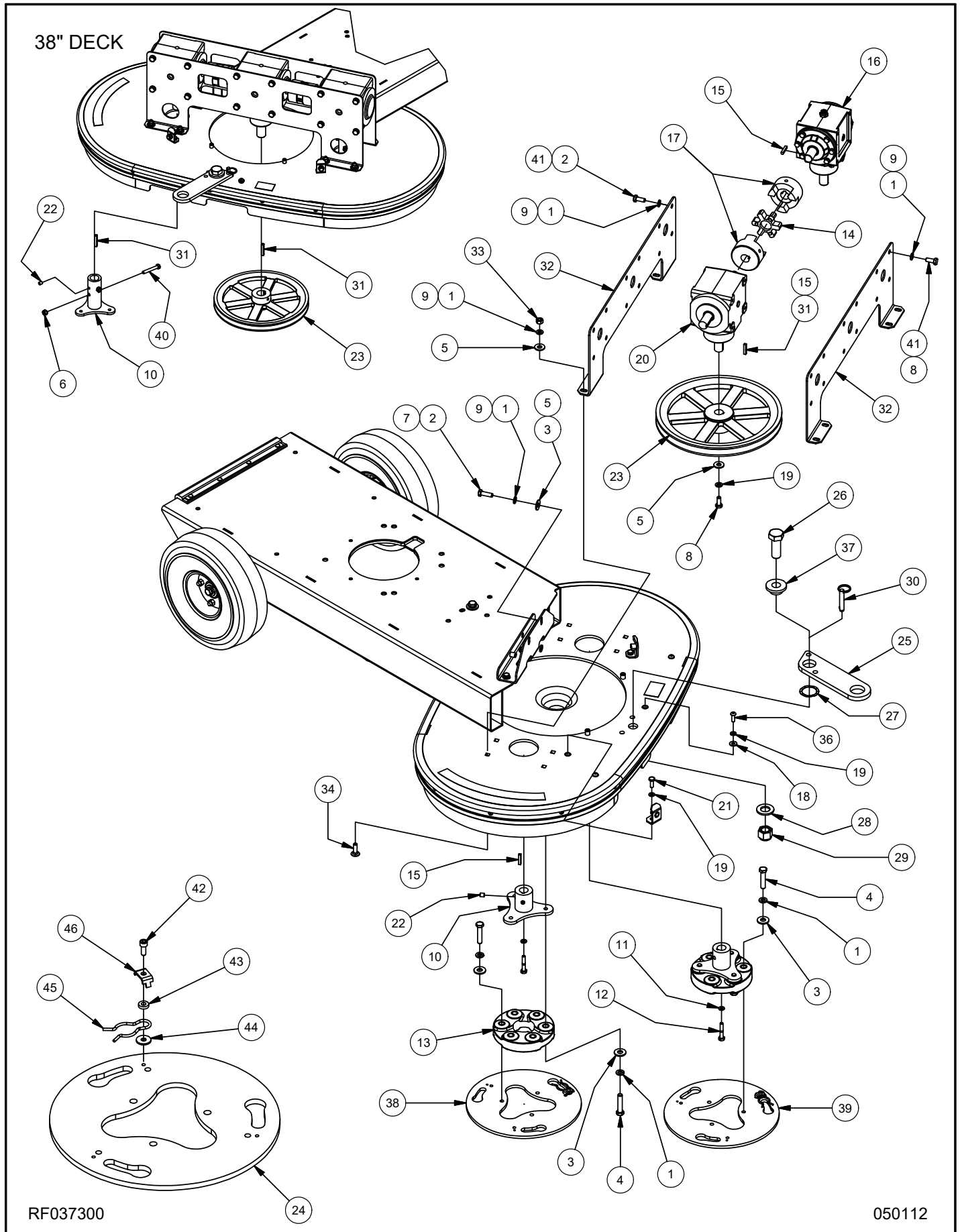

Main Assembly - Deck (continued)

<u>Item</u>	<u>Ref. No.</u>	<u>Description</u>	<u>Qty</u>	<u>Item</u>	<u>Ref. No.</u>	<u>Description</u>	<u>Qty</u>
1A	MX1075	WASHER, LOCK, 3/8" (30")	12	21	NB019100	BOLT, HEX, 1/4" X 3/4"	2
1B	MX1075	WASHER, LOCK, 3/8" (38")	36	22	NB2463	SCREW, SET, 5/16" X 3/8"	4
2	NB6042	BOLT, HEX, 3/8" X 1-1/4" (38")	2	23A	MP037600	PULLEY, 10.75" X 3/4" (30")	1
3A	NB3450	WASHER, FLAT, 3/8" (30")	12	23B	MP037300	PULLEY, 10.75" X 1" (38")	1
3B	NB3450	WASHER, FLAT, 3/8" (38")	14	24	MP331100	PLATE, ATTACH, HEAD	1
4	NB024500	BOLT, HEX, 3/8" X 1-3/4"	12	25	MP397901	PLATE, PIVOT, HOOK	1
5A	NB9267	WASHER, FLAT, 5/16" (30")	31	26	NB035400	BOLT, HEX, 3/4" X 2-1/2"	1
5B	NB9267	WASHER, FLAT, 5/16" (30")	38	27	NB033500	WASHER, WAVE	1
6	NB3265	NUT, LOCK, 5/16" (38")	2	28	NB018600	WASHER, FLAT, 3/4"	1
7	NB6545	BOLT, HEX, 5/16" X 1" (30")	2	29	NB035500	NUT, LOCK, 3/4"	1
8	NB9745	BOLT, HEX, 5/16" X 3/4"	23	30	NB035800	PIN, PULL, 3/8" X 1-1/2"	1
9A	NB6111	WASHER, LOCK, 5/16" (30")	32	31	NB7802	KEY, 1/4" X 1-1/2"	3
9B	NB6111	WASHER, LOCK, 5/16" (38")	8	32A	MP388401	BRACKET, GEARBOX (30")	2
10A	BA018500	HUB, DRIVE, 3/4" (30")	2	32B	MP388701	BRACKET, GEARBOX (38")	2
10B	BA019100	HUB, DRIVE, 1" (38")	2	33	NB3260	NUT, HEX, 5/16"	8
11	NB025700	WASHER, LOCK, 1/4" (30")	2	34	NB5000	BOLT, CARRIAGE, 5/16" X 1"	8
12	NB030500	BOLT, HEX, 1/4" X 1-1/2" (30")	2	35	MP391800	BRACKET, COVER, ASM.	2
13	MP317700	COUPLING, FLEXI	2	36	NB049000	SCREW, BH, 1/4" X 3/4"	1
14	MP037500	SPIDER, L099, 1"	2	37	MP389200	BUSHING, PIVOT, HOOK	1
15A	BA003200	KEY, 3/16" X 1" (30")	7	38	MP390700	PLATE, ATTACH, RS, ASM.	1
15B	MP7801	KEY, 1/4" X 1" (38")	4	39	MP390800	PLATE, ATTACH, LS, ASM.	1
16A	MP363200	GEARBOX, RIGHT ANGLE (30")	2	40	NB011800	BOLT, HEX, 5/16" X 2"	2
16B	BA017500	GEARBOX, RIGHT ANGLE (38")	2	41	NB6851	BOLT, HEX, 3/8" X 3/4"	22
17A	MP196700	HUB, L099, .75" BORE (30")	4	42	NB060500	SCREW, #10 X 1/2"	1
17B	MP037400	HUB, L099, .1.00" BORE (38")	4	43	NB060600	WASHER, .20" ID X .44" OD	1
18	NB3350	WASHER, FLAT, 1/4"	1	44	NB060700	WASHER, .22" ID X .63" OD	1
19	NB6110	WASHER, LOCK, 1/4"	3	45	NB024100	PIN, HITCH	1
20A	BA017200	GEARBOX, "T" DRIVE (30")	1	46	MP098700	RETAINER, PIN	1
20B	BA017400	GEARBOX, "T" DRIVE (38")	1				

Regulator, Handle, & Hood Assembly

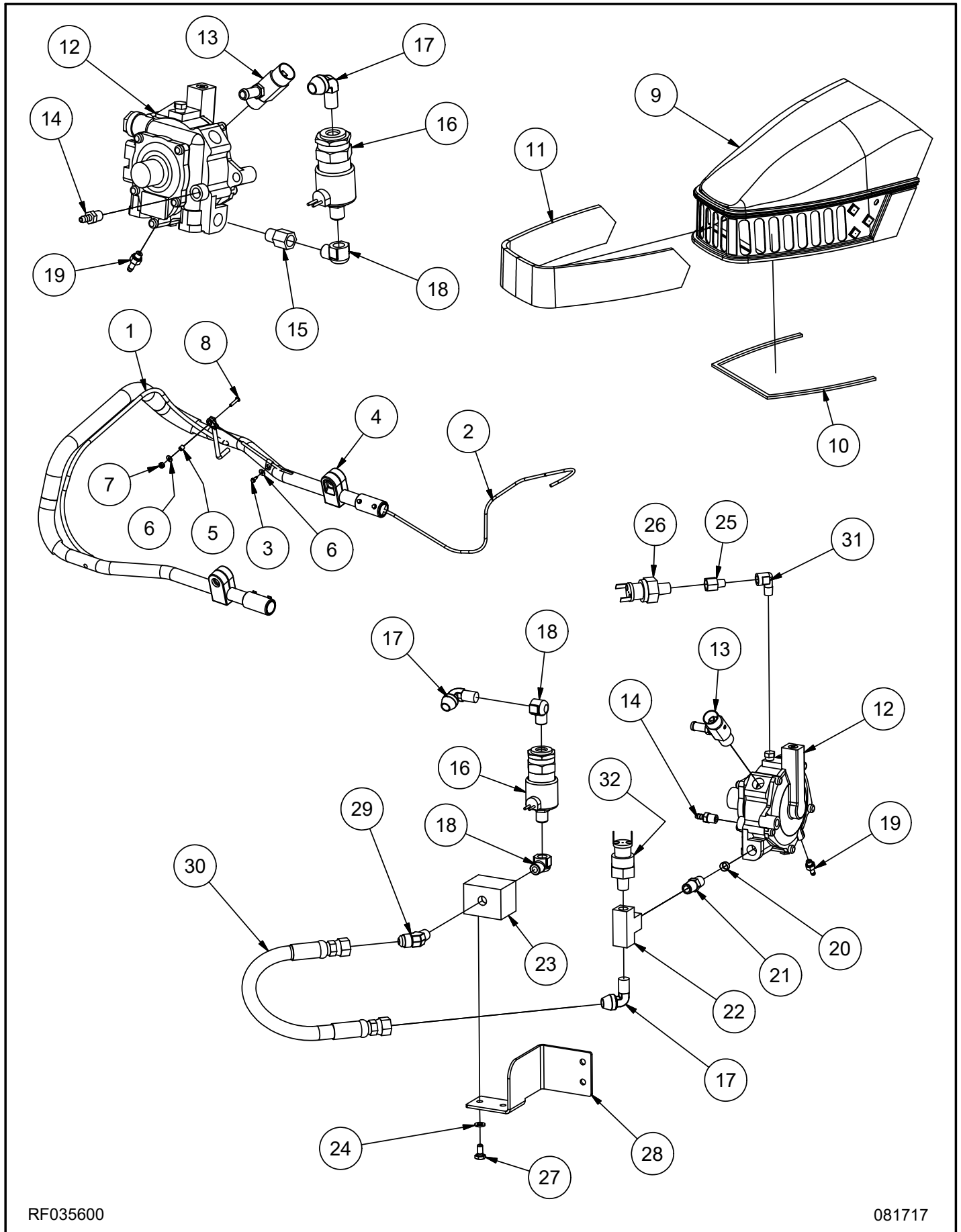

RF035600

081717

Regulator, Handle, & Hood Assembly (continued)

<u>Item</u>	<u>Ref. No.</u>	<u>Description</u>	<u>Qty</u>	<u>Item</u>	<u>Ref. No.</u>	<u>Description</u>	<u>Qty</u>
1	MP042000	BAIL, BACK	1	20	MP341500	SCREEN, INLET, REGULATOR	1
2	MP106500	CABLE, CONTROL, THROTTLE	1	21	MP4325	FITTING, 3325 X 4, REG TO FUELOCK	1
3	NB4382	SCREW, #8 X 1/2"	5	22	MP509300	FITTING, TEE, 1/4" FNPT	1
4	MP050500	BLOCK, GUIDE, CABLE	1	23	MP509600	MANIFOLD, SAFE STOP	1
5	NB028300	BUSHING, CABLE	1	24	NB6110	WASHER, LOCK, 1/4"	2
6	NB9645	WASHER, FLAT, #10	2	25	MP509900	FITTING, 1/8" MNPT X 1/4" FNPT	1
7	NB9735	NUT, LOCK, #10	1	26	MP509800	SWITCH, PRESSURE, 6 PSI	1
8	NB049100	SCREW, #10 X 7/8"	1	27	NB015700	SCREW, CAP, HH, 1/4 -20 X 5/8	2
9	MP375800	HOOD, BLACK, ASM.	1	28	MP522201	BRACKET, MANIFOLD, 440ST	1
10	MP075200	FOAM, 1/2" X 38"	1	29	MP4331	FITTING, 54 X 6, REG TO FUELOCK	1
11	MP373400	FILTER, AIR, HOOD	1	30	MP4340	HOSE, FUEL, LP, 13", ASM.	1
12	SA026300	REGULATOR, LP	1	31	MP098900	FITTING, 1/8" MPT X 1/8" FPT 90	1
13	MP017900	ADJUSTMENT, FUEL, ASM.	1	32	MP509200	SWITCH, PRESSURE, 200 PSI	1
14	MP019500	FITTING, HB, 1/8" NPT	1				
15	MP027100	FITTING, EXTENSION	1				
16	MP317500	FUELOCK, ASM.	1				
17	MP4330	FITTING, ELBOW	1				
18	MP027200	FITTING, ELBOW, 1/4" NPT	1				
19	MP371100	FITTING, HB, 1/4-28	1				

Transport Cart Assembly

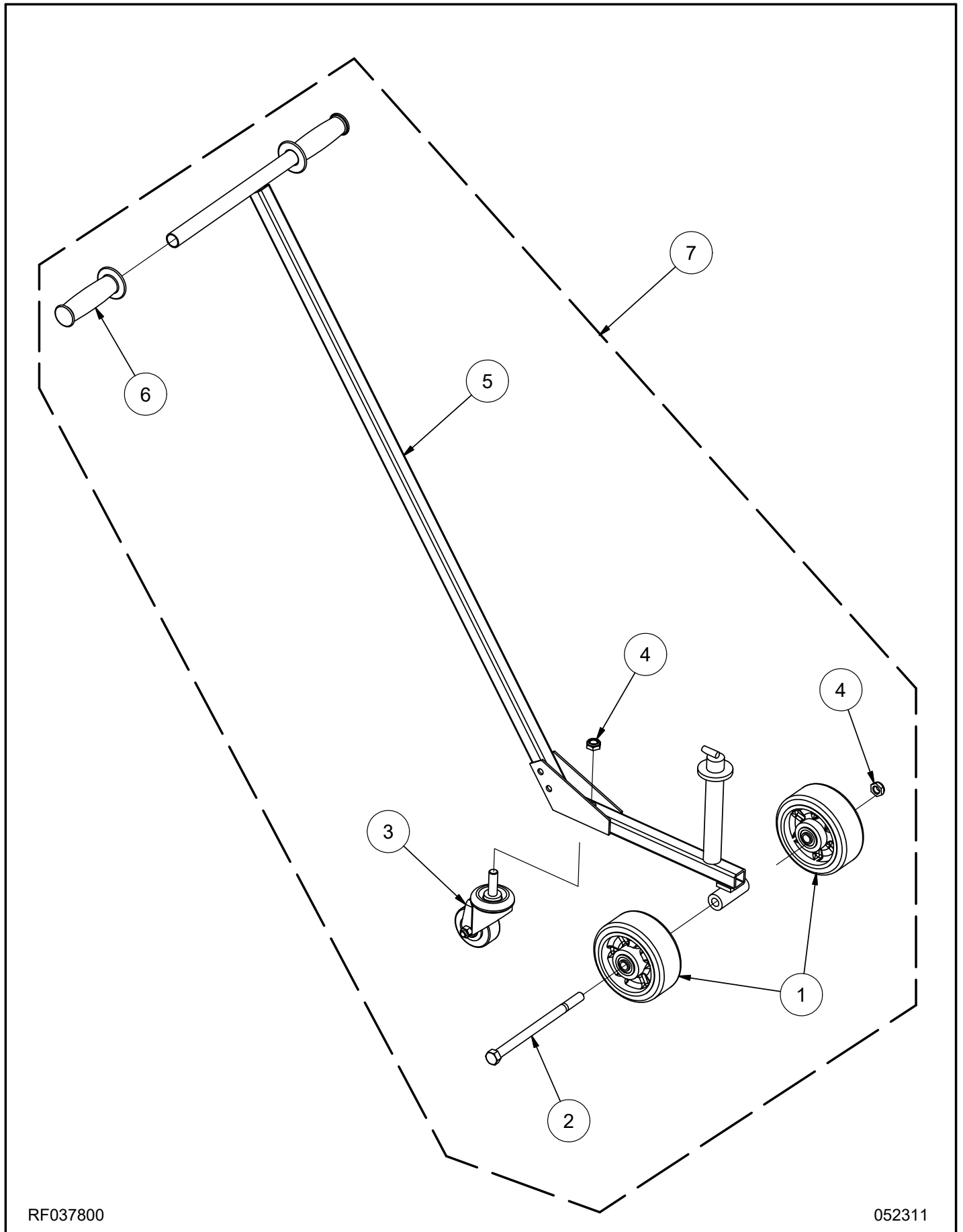

RF037800

052311

Transport Cart Assembly (continued)

<u>Item</u>	<u>Ref. No.</u>	<u>Description</u>	<u>Qty</u>
1	MP352600	WHEEL, 5" X 2"	2
2	NB056000	BOLT, HEX, 1/2" X 8"	1
3	MP012800	CASTER, SWIVEL, 2-1/2"	1
4	NB003100	NUT, JAM, LOCK, 1/2"	1
5	MP389400	CART, TRANSPORT	1
6	MP366900	GRIP, HANDLE	2
7	MP389300	CART, TRANSPORT, ASM.	1

Small Off-Road Engine Certification Warranty Form

Emission Control Warranty Statement

Your Warranty Rights and Obligations

The California Air Resources Board and Amano Pioneer Eclipse Corporation is pleased to explain the emissions control system's warranty on your 2016 small off-road engine. In California, new equipment that use small off-road engines must be designed, built, and equipped to meet the State's stringent anti-smog standards. Amano Pioneer Eclipse Corporation must warrant the emissions control system on your small off-road engine for the period listed below provided there has been no abuse, neglect or improper maintenance of your equipment. Your emissions control system may include parts such as: carburetor's or fuel injection system, ignition system, catalytic converters, fuel tanks, valves, filters, clamps, connectors, and other associated components. Also, included may be hoses, belts, connectors, sensors, and other emission-related assemblies. Where a warrantable condition exists, Amano Pioneer Eclipse Corporation will repair your small off-road engine at no cost to you including diagnosis, parts and labor.

Manufacturer's Warranty Coverage

This emissions control system is warranted for two years. If any emissions-related part on your equipment is defective, the part will be repaired or replaced by Amano Pioneer Eclipse Corporation.

Owner's Warranty Responsibilities

- (a) As the small off-road engine owner, you are responsible for performance of the required maintenance listed in your owner's manual. Amano Pioneer Eclipse Corporation recommends that you retain all receipts covering maintenance on your small off-road engine, but Amano Pioneer Eclipse Corporation cannot deny warranty solely for the lack of receipts or your failure to ensure the performance of all scheduled maintenance.
- (b) As the small off-road engine owner, you should however be aware that Amano Pioneer Eclipse Corporation may deny you warranty coverage if your small off-road engine or a part has failed due to abuse, neglect, or improper maintenance or unapproved modifications.
- (c) You are responsible for presenting your small off-road engine to an Amano Pioneer Eclipse Corporation distribution center or service center as soon as the problem exists. The warranty repairs should be completed in a reasonable amount of time, not to exceed 30 days. If you have a question regarding your warranty coverage, you should contact Amano Pioneer Eclipse Corporation at 1-800-367-3550.

Defects Warranty Requirements

- (A) The warranty period begins on the date the engine or equipment is delivered to an ultimate purchaser.
- (B) **General Emissions Warranty Coverage.** Amano Pioneer Eclipse Corporation as the manufacturer of each small off-road engine or equipment must warrant to the ultimate purchaser and each subsequent owner that the engine or equipment is:
 - (1) Designed, built, and equipped so as to conform with all applicable regulations adopted by the Air Resources Board; and
 - (2) Free from defects in materials and workmanship that causes the failure of a warranted part for a period of two years.
- (C) The warranty on emissions-related parts will be interpreted as follows:
 - (1) Any warranted part that is not scheduled for replacement as required maintenance in the written instructions required by subsection (D) must be warranted for the warranty period defined in Subsection (B2). If any such part fails during the period of warranty coverage, it must be repaired or replaced by the manufacturer according to Subsection (C4) below. Any such part repaired or replaced under the warranty must be warranted for the remaining warranty period.
 - (2) Any warranted part that is scheduled only for regular inspection in the written instructions required by subsection (D) must be warranted for the warranty period defined in Subsection (B2). A statement in such written instructions to the effect of "repair or replace as necessary" will not reduce the period of warranty coverage. Any such part repaired or replaced under warranty must be warranted for the remaining warranty period.

- (3) Any warranted part that is scheduled for replacement as replacement as required maintenance in the written instructions required by subsection (D) must be warranted for the period of time prior to the first scheduled replacement point for that part. If the part fails prior to the first scheduled replacement, the part must be repaired or replaced by the engine manufacturer according to Subsection (C4) below. Any such part repaired or replaced under warranty must be warranted for the remainder of the period prior to the first scheduled replacement point for the part.
- (4) Repair or replacement of any warranted part under the warranty must be performed at no charge to the owner at a warranty station.
- (5) Notwithstanding the provisions of Subsection (C4) above, warranty services or Repairs must be provided at all manufacturer distribution centers that are franchised to service the subject engines.
- (6) The owner must not be charged for diagnostic labor that leads to the Determination that a warranted part is in fact defective, provided that such diagnostic work is performed at a warranty station.
- (7) The manufacturer is liable for damages to other engine components Proximately caused by a failure under warranty of any warranted part.
- (8) Throughout the emissions warranty period defined in Subsection (B2), the manufacturer must maintain a supply of warranted parts sufficient to meet the expected demand for such parts.
- (9) Any replacement part may be used in the performance of any warranty Maintenance or repairs and must be provided without charge to the owner. Such use will not reduce the warranty obligations of the manufacturer.
- (10) Add-on or modified parts that are not exempted by the Air Resources Board may not be used. The use of any non-exempted add-on or modified parts will be grounds for disallowing a warranty claim. The manufacturer will not be liable to warrant failures of warranted parts caused by the use of a non-exempted add-on or modified part.
- (11) The manufacturer issuing the warranty shall provide any documents that describe that manufacturer's warrant procedures or policies within five working days of request by the Air Resources Board.

(D) Emission Warranty Parts List

- (1) Fuel Metering System
 - (a) Carburetor, internal parts, and pressure regulator.
 - (b) Cold start enrichment system.
- (2) Air Induction System
 - (a) Intake manifold.
 - (b) Air filter.
- (3) Ignition System
 - (a) Spark Plugs.
 - (b) Magneto or electronic ignition system.
 - (c) Spark advance/retard system.
- (4) Exhaust System
 - (a) Exhaust manifold.
- (5) Miscellaneous Items Used in Above Systems
 - (a) Electronic Fuel Cut-off control.
 - (b) Vacuum, temperature, time sensitive valves, and switches.
 - (c) Hoses, belts, connectors, and assemblies.

Amano Pioneer Eclipse Corporation will furnish with each new engine written instructions for the maintenance and use of the engine by the owner.

Exception: This warranty does not apply to any machine models that do not have a catalyst muffler.



SAFETY AWARENESS FORM FOR PROPANE MACHINES

The following must be completed before an employee may use a propane machine!

I have read the "Operators Manual" and understand it.

Name:

Date:

(Print or Type)

Demonstrate to your instructor that you can do the following properly and safely:

How to prepare the propane machine for operation:

- A. Install pads.....
- B. Check oil.....
- C. Adjust handle.....
- D. Check fuel cylinder for overfilling.....
- E. Install fuel cylinder.....
- F. Do you have a MSDS for propane?.....

How to operate a propane machine:

- A. Start and stop the engine.....
- B. Emergency stop.....
- C. Clean air filter.....

Cautions:

- A. Allow only qualified, trained personnel to operate the machine.
- B. Use only D.O.T. approved fuel cylinders supplied by Amano Pioneer Eclipse.
- C. Always store fuel cylinders outside in a proper enclosure.
- D. Never vent a fuel cylinder inside.
- E. Always wear a CO detector badge.
- F. Never leave the machine running unattended.
- G. Know what to do and whom to call in case of emergency.

When all items are checked off and this form is signed by an instructor or supervisor, you may operate a propane machine.

Employee Signature: _____

Date: _____

Instructor/Supervisor Signature: _____

Date: _____



Amano Pioneer Eclipse Corporation

1 Eclipse Rd ● PO Box 909
Sparta, North Carolina 28675 ● USA
www.pioneereclipse.com

+1-336-372-8080
1-800-367-3550
Fax +1-336-372-2913

EC Machinery Directive 2006/42/EC,
EC Restriction of Hazardous Substances Directive (2011/65/EU)
Harmonized Standards Applied: EN 12100-1, EN12100-2